

長期依存性に基づいた OC48c 回線に対するトラフィック試験装置

田上 敦士, 長谷川 輝之, 長谷川 亨, 中尾 康二

KDDI 研究所

あらすじ:

トラフィックの急激な増加により OC-48 や OC-192 のような高速な回線がインターネットのバックボーンとして使用され始めている。そのような高速な回線において新規サービスやアプリケーションを導入するには、事前の実環境におけるネットワーク試験は重要である。特にネットワーク試験において正しい実験結果を得るために、現実的なバックグラウンド負荷をかけることが重要である。現在一般に使用されているトラフィック試験装置で用いている MMPP や MAP などのトラフィックモデルは、現実のトラフィックを模擬することが困難であることが近年の研究で明らかになっている。そこで、筆者らはインターネットのトラフィックモデルとして注目されている長期依存性を持ったトラフィックを生成する装置の開発した。本稿では試験装置の実装について述べる。

OC-48c Traffic Tester with Long-range Dependence Characteristics

Atsushi TAGAMI, Teruyuki HASEGAWA, Toru HASEGAWA and Koji NAKAO

KDDI R&D Laboratories Inc.

Abstract

It is important to use suitable background traffic at the network experiments for validating OC-48c or OC-192c based high-speed Internet backbones. MMPP (Markov Modulated Poisson Process) and MAP (Markov Arrival Process), which are used to generate background traffic, are so simplistic that the network experiments may produce misleading results. In order to solve the problem, we have developed an OC-48c traffic tester for generating and analyzing long-range dependence traffic because the traffic model is considered one of the most realistic traffic models. The traffic tester achieves the OC-48 rate traffic generation using the hardware logic.

1. Introduction

High-speed links such as 2.5 Gbps OC-48 links and 10 Gbps OC-192 links need to be used as backbone links of the Internet in order to accommodate rapidly increasing Internet traffic. Many high-speed test beds have been constructed [1], and network experiments have been enthusiastically performed in order to validate high-speed Internet backbones. Network equipments such as gigabit routers and layer 2 switches are tested to check whether they can handle packets at the speed of 2.5 Gbps and 10 Gbps. Performances of TCP based applications and real time applications are measured under various kinds of background traffic to check whether they perform well over the high speed Internet. However, the experiment results are sensitive to characteristics of the background traffic. For example, when bursty traffic is used, measured

packet transfer delays are large, compared with constant traffic. It is important to choose suitable background traffic in order to get accurate results.

There have been studies on generating test traffic [2], used as background traffic. MMPP (Markov Modulated Poisson Process) and MAP (Markov Arrival Process) have been used as traffic models to generate the test traffic. Many commercial traffic testers [3] use these models. However, MMPP and MAP are so simplistic to model the real traffic of the Internet that the network experiments may produce misleading results.

The recent studies [4][5] have made it clear that the Internet traffic has long-range dependence characteristics, which are not modeled by either MMPP or MAP. It has become an important theme to generate long-range dependence traffic because the traffic model is considered one of the most realistic traffic models. There has been a

study [6] on generating the long-range dependence traffic. In this study, a traffic tester has been developed to generate a long-range dependence ATM cell stream at 155Mbps OC-3 rate. However, this method cannot generate a variable size IP packet stream over a POS (Packet over Sonet) link because it assumes that an IP packet is segmented to fixed size ATM cell. Moreover, this tester cannot scale to a packet stream generation at OC-48 rate because of the software implementation.

The above traffic testers [3] have another serious problem. In order to generate the realistic traffic, it is inevitable to analyze the long-range dependence characteristics for the traffic captured from an Internet backbone link. This requires the tester to capture packets for a long duration; however, most testers just capture packets for less than 1 second when the link rate is OC-48.

In order to solve the two problems, we have developed an OC-48c traffic tester for generating and analyzing long-range dependence traffic. The tester consists of an OC-48c communication board and a host computer. The features of the tester are summarized as follows:

- The traffic generation at OC-48 rate is achieved by the hardware logic.
- Time series data which consist of either packets or bytes are used to represent traffic which is transmitted or analyzed.
- Long-range dependence traffic is calculated as time series data on a host computer, and an OC-48c communication board turns the time series data into an IP packet stream.
- Captured packets are turned into the time series data, and the data are save at a memory of the board. This makes it possible to save the time series data for a long duration, e.g., 4 hours.

The OC-48c traffic tester is the first implementation which succeeds in generating long-range dependence traffic at OC-48 rate in the world.

The rest of paper is organized as follows. In section 2, we explain the overview of the tester, after introducing long-range dependence of traffic. In section 3, we describe the implementation overview. In section 4, we describe the results of tester experiments.

2. Overview of OC48c Tester

2.1 Long Range Dependence Traffic

Traffic models for long-range dependence are defined using the following framework. Consider a stationary time series $X = \{X_t : t = 0, 1, 2, \dots\}$, for example, representing the number of packets one time interval observed on a given link. We define

the m -aggregated series $X^{(m)} = \{X_k^{(m)} : k = 1, 2, 3, \dots\}$ by summing the original series X over non-overlapping blocks of size m . Then it has the same autocorrelation function $r(k) = E[(X_t - \mu)(X_{t+k} - \mu)]$ as the series $X^{(m)}$ for all m .

If X has long-range dependence characteristics, an autocorrelation function $r(k)$ has the characteristics shown in expression (1).

$$r(k) \sim k^{-\beta} \text{ as } k \rightarrow \infty, \text{ where } 0 < \beta < 1 \quad (1)$$

Thus the autocorrelation function of such a process decays hyperbolically. Hyperbolically decay is much slower than exponential decay, and since $\beta < 1$, the sum of the autocorrelation values of such a series approaches infinity. This description is closely associated to self-similarity and a Hurst parameter which is defined by the equation (2) [6].

$$H = 1 - \beta/2 \quad (2)$$

2.2 Functions of OC-48c Traffic Tester

Figure 1 shows how the OC-48c traffic tester is used at network experiments of high speed Internet backbone. Time series data, which are used to define long-range dependence traffic, are a sequence of packet numbers or byte numbers which are transferred in fixed intervals. The packet number or byte number in an interval represents a transfer rate.

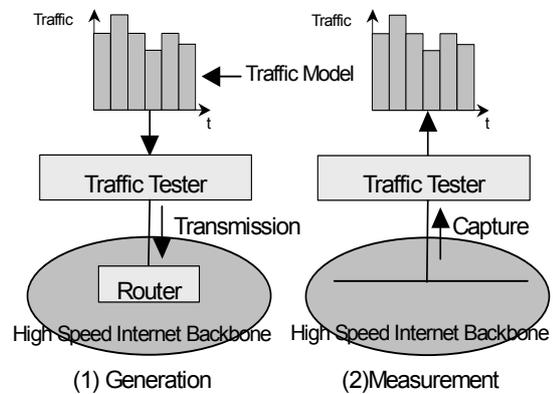

Figure 1: Function of OC-48c Traffic Tester

(1) Traffic generation

The tester is used as a traffic generator. The tester turns time series data calculated in advance into a packet stream with long-range dependence, and transmits the stream to an OC-48c link (Figure 1- (1)). This traffic is used as background traffic when new applications or new services are introduced into high-speed Internet backbones. And, it is expected to be used as a reference load for benchmarking network equipments.

(2) Traffic measurement

The tester is uses as a traffic monitor. The tester

captures packets on an OC-48c link, and creates the time series data of either packet numbers or bytes (Figure 1 - (2)). It is possible to analyze the long-range dependence characteristics by calculating Hurst parameter from the time series data.

The analysis results are applied to various objectives. The results are expected to make clear the traffic characteristics of the next generation high-speed. The analysis results such as Hurst parameters are used to generate more realistic traffic at (1) of section 2.2. This feedback makes it possible to rebuild the traffic model for generating the background traffic.

2.3 Requirements to OC-48c Traffic Tester

(1) Interval Granularity

The interval value of time series data must be carefully chosen. If the interval were smaller, which is desirable from the point of view of specifying the traffic rate very precisely, all details of the series would be lost. This is because a range of packet number or byte number in an interval becomes small. Table 1 shows maximum number of packets and bytes in interval times for 1ms, 10ms, 100ms and 1000ms, when the link rate is OC-48 rate. For example, 59 packets are transmitted under 100ms when 512 bytes packets are continuously transmitted. If we selected 1ms as an interval, it could not transmit even one packet whose length is 1500 byte. At least, interval of several ms are too small to reproduce the specified traffic rate. From the experiences of the past study [6], maximum packet number in an interval had better be about 100. Therefore, we have chosen the following three intervals: 10ms, 100ms and 1000ms.

Table 1: Maximum Number of Packets and Bytes in An Interval For OC-48c Link

interval	packets			bytes
	40	512	1500	
1ms	7	0	0	300
10ms	75	6	2	3000
100ms	750	59	20	30000
1000ms	7500	585	200	300000

(2) Generation Duration

Traffic testers must transmit the traffic for more than several minutes. When the traffic is used as the background traffic, more than several minutes are required to measure correctly the performance of application. For example, TCP performance tests using test software *ttcp* and *netperf* usually take more than 180 seconds.

(3) Reproduction

It is inevitable for traffic testers to generate completely the same traffic at any time on the same

conditions. Usually, similar network experiments are repeated only changing some parameter values of routers, application protocols and so on. The background traffic generated by the tester is expected to be the same in order to exclude the background traffic difference.

(4) IP Packet Generation

An element of time series data is either number of packets or bytes. The size of each packet is not determined in the time series data for the above two forms. This is different from ATM cell generation method [6] in which the size of cell is fixed. It is necessary for our traffic tester to determine the size of each packet.

There has been study [7] on analyzing packet size distribution over a specific duration. However, the generation probability of packets has not been analyzed. Therefore, the traffic tester takes the following approach: The packet size distribution can be specified by users. The tester chooses a packet size for each packet independently using the distribution.

3. Implementation of OC-48c Traffic Tester

3.1 Overview

The OC-48c traffic tester consists of an OC-48c communication board and an Intel PC (Personal Computer) running Windows NT.

(1) Time Series Data

The traffic tester has been designed to deal with the both forms of time series data: packets and bytes. Any traffic, which is difficult to be modeled by a sequence of packet intervals, can be generated. On the contrary, the traffic tester receives a stream of IP packets, and creates time series data of packets or bytes.

(2) Hardware Logic Implementation

The interval should be 10 μ s, 100 μ s and 1000 μ s in order to generate a packet stream at OC-48 rate, as described in section 2.3 (1). Besides, the traffic tester is required to generate the same packet stream from the same time series data, as described in section 2.3 (3). In order to satisfy the both requirements, we have decided to implement all the procedures of packet stream generation and measurement only using hardware logic in an FPGA (Field Programmable Gate Array).

(3) Memory and Time Series Data Format

Time series data are stored at a memory of an OC-48c communication board before the tester starts generating an IP packet stream because the memory is not accessed by the FPGA and the host PC at the same time. Each element of time series data is 16 bit long, and the memory size is 64 M bytes. First, about 30,000 bytes are transferred

within 100 ms at OC-48 rate, as shown in Table 1. This requires an element of time series data to be at least a 15 bit long integer. Second, the size of memory is large enough to save more than 50-minute time series data for 100 ms intervals.

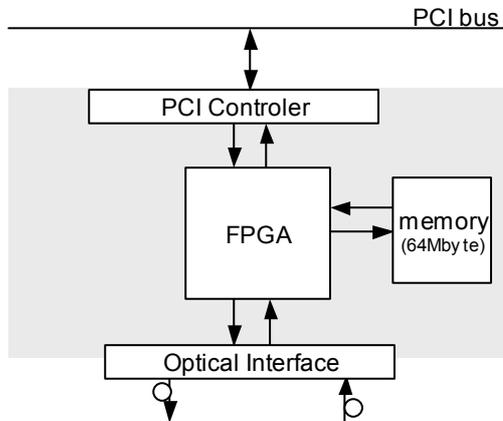

Figure 2: Block Diagram of OC-48c Communication Board

Table 2 shows the generation duration, measurement duration for the supported three intervals. The measurement duration is half to the generation duration because the two kinds of time series data for successful packets and error packets.

Table 2: Generation and Measurement Duration

Interval	Generation	Measurement
10ms	5 min.	2.5 min.
100ms	50 min.	25 min.
1000ms	8 h 20 min.	4 h 10 min.

(4) IP Packet Generation

Since an element of time series data just specifies the number of packets or bytes, the traffic tester needs to create an IP packet with some principle. The traffic tester determines a packet size based on a packet size distribution specified by users. A packet size distribution is a table each of which link consists of a packet size and a generation probability, as shown in Table 3. 7 bits are assigned to represent the generation probability. In other words, 1/128 is the smallest value of the generation probability.

First, the traffic tester makes an array which consists of 128 elements, and each element is one of the packet sizes of the above table. The element number of each packet size is determined from the generation probability. For example, 50 elements are 1500 byte packet size. Second, when an IP packet is created, the traffic tester generates a random value, and uses the packet size of the array whose index is the modulo 128 of the random value.

On the contrary, the traffic tester randomly determines a source address and a destination address of IP packet from ranges of source and

destination addresses specified by users.

Table 3: Example of Packet Size Distribution Table

Packet size [byte]	Probability	
1500	39.06250	50/128
700	3.12500	4/128
600	2.34325	3/128
512	10.15625	13/128
40	44.53125	57/128

3.2 OC-48c Communication Board

We have developed an OC-48c communication board, illustrated in Fig. 2. The board consists of a FPGA, 64Mbyte memory, a PCI bus interface, and an OC-48c optical interface. This board is a full-size PCI card. An FPGA is a programmable device (ALTERA FLEX10K250E-1); therefore, any logic of handling packets is built into the FPGA. The logic for generating and analyzing packets is built into the FPGA. 50 MHz clock is used to drive the FPGA because a 50MHz/64bit interface is provided by the optical interface. The 50 MHz clock is enough fast to transmit and receive packets at OC-48 rate. The memory is an SDRAM chip, and it is accessed by the FPAG and the PC. Time series data and the control data are saved at the memory. The PC and the communication board are connected via a 32bit/33MHz PCI bus. The optical interface consists of a POS (Packet Over SONET) framer, a transmitter, a receiver and an optical transceiver.

3.3 Traffic Generation

An IP packet stream with long-range dependence is generated and transmitted to an OC-48c link according to the following procedure, as shown in Fig. 3.

(1) Time Series Data Creation

First, users create time series using some traffic models such as FGN (Fractal Gaussian Noise) [8] and ON/OFF [9] models on a host PC. The calculated times series data is saved as a file, which contains integer values in a text form. Second, users create the following control data: an interval time, a flag which specifies either packet number or byte number, a packet size distribution, ranges of source and destination address, and a seed of random numbers.

(2) Initialization

The OC-48c communication board is initialized in the following way: The time series data and the control data are transferred to a memory of an OC-48c communication board. A counter for packets or bytes is set at zero. The counter is used to record how many packets or bytes must be transmitted for a current interval. After the initialization, either procedures (3) and (4-1) or

procedures (3) and (4-2) are independently repeated until the end.

(3) Counter Process at Every Interval

Every interval (10 ms, 100 ms or 1000 ms), an interval beginning is signaled. The logic of FPGA reads a next element of the time series data from the memory, and adds it to the counter.

(4-1) and (4-2) are used for time series data of packets and bytes, respectively

(4-1) Creation and Transmission of IP packet for Packets

An IP packet is created when one of the following conditions is satisfied:

- The counter becomes more than one from zero.
- The counter is more than one when a previous IP packet transmission finishes.

The logic of FPGA creates an IP packet and decreases the counter by one. The packet size, and source and destination addresses are determined as shown in section 3.1 (4). Then, it transmits the IP packet to an OC-48c link.

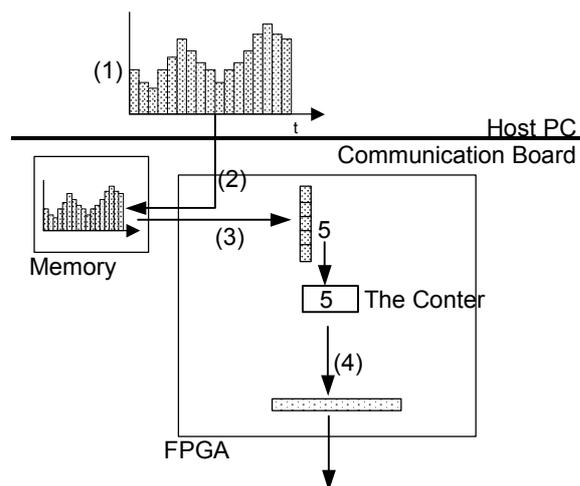

Figure 3: Procedure of Generation

(4-2) Creation and Transmission of IP Packet for Bytes

An IP packet is created when one of the above conditions is satisfied. The logic of FPGA creates an IP packet. If the size of packet, which is determined according to the procedure at section 3.1 (4), is less than or equal to the counter value, it transmits the IP packet, and decrease the counter by the packet size. Otherwise, it waits for the counter value to become more than or equal to the packet size. Usually, at the next interval beginning, the counter is incremented so that the above condition is satisfied. Then, it transmits the waiting IP packet, and decreases the counter

3.4 Traffic Measurement

The traffic tester captures an IP packet stream,

and turns them into time series data according to the following procedure:

(1) Initialization

Two parameters, interval time and a kind of time series data, are stored in a memory on an OC-48c communication board. Then, two counters for packets or bytes are set at zero. In case of packets, the counters are used to show how many successful packets and error packets are received for a current interval, respectively.

(2) Packet Capture

When the tester captures a correct IP packet, the logic of FPGA increases the counter for successful packets. When the tester captures an error packet, e.g. CRC error packet, it increases the counter for error packets.

(3) Time Series Data Creation

Every when an interval end is signaled, the logic of FPGA writes the counter values at the next elements of the both time series data on the memory. Then it sets the counters at zero.

(4) Transfer to Host PC

When the measurement is stopped, the time series data are read from the memory, and are transferred to a file on host PC's disk.

4. Experiments

We have performed the long-range dependence traffic generation experiments. The aim of these experiments is to know how accurately the OC-48c traffic tester generates IP packet streams.

(1) Time Series Data Creation

Time series data of 10,000 elements are created using the FGN [8] which is the most widely-studied long-range dependence process. The FGN process uses the three parameters: an average, a variance and a Hurst parameter. These three values are set at 100, 100 and 0.81 respectively. The time series data are shown in Fig. 4 (1).

(2) Generation and Measurement

An IP packet stream is generated and transmitted on the following: The time series data are used to represent a packet number sequence. 1000 ms is used as an interval. An IP packet stream is transmitted for 10 seconds. The packet size distribution is shown in Table 3.

The two OC-48c traffic testers are directly connected. One tester transmits an IP packet stream, and the other tester receives the stream and creates the time series data. The measured time series data are shown in Fig.4 (2).

(3) Comparison between Original and Measured Time Series Data

First, at least to the eye, the measured time series data appears to be an exact copy of the original

target time series. When comparing values of the corresponding intervals, there are few intervals whose values are different. Second, we have calculated a Hurst parameter of the measured time series data. Figure 5 (1) and (2) show the

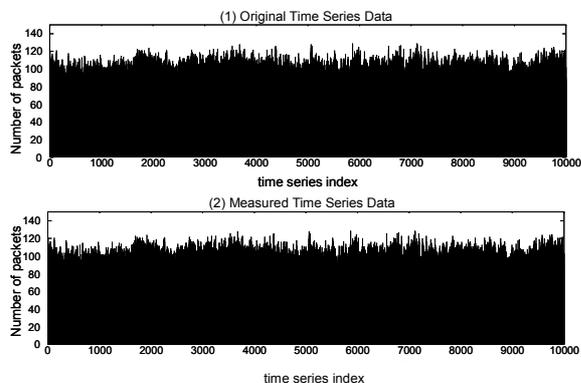

Figure 4: Example Time Series and Measured Time Series

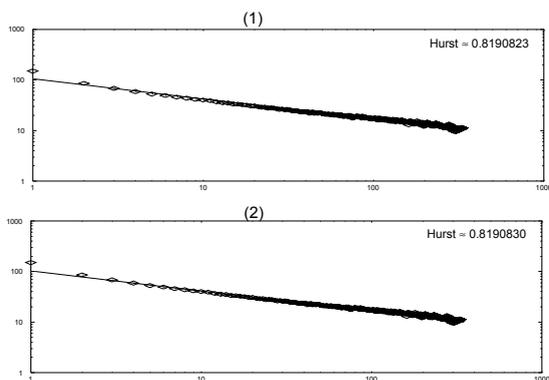

Figure 5: Variable-time Plots

variance-time plots for the original time series data and the measured time series data. The Hurst parameters are almost as the same, and the shapes of plots appear to be the same to the eye.

5. Conclusion

The generation of realistic background test traffic at OC-48 rate is an important topic because network equipment and application performance experiments are urgently performed in order to validate high-speed Internet backbones. Most traffic testers use MMAP and MAP to generate a background test traffic; however, MMAP and MAP are so simple traffic models that network experiments using such a traffic may produce misleading results. In order to solve the problem, we have developed an OC-48c traffic tester for generating and analyzing long-range dependence traffic at OC-48 rate because the traffic model is considered one of the most realistic traffic models. The traffic tester achieves the long-range

dependence traffic generation according to the following elaborations: First, OC-48 rate traffic generation is achieved using the hardware logic of FPGA on the OC-48c communication board. Second, the tester enables the long-range dependence traffic generation by representing a traffic data as a time series of packets or bytes. As a result of various experiments, we have made it clear that the traffic tester accurately generates and transmit an IP packet stream with long-range dependence characteristics. This is the first implementation of such a traffic at OC-48 rate in the world. Besides, the traffic tester is used to create a time series data from captured packets on a OC-48c line. We believe that the OC-48c traffic tester will have an important roll to generate a realistic background traffic at network experiments, and to analyze the long-range dependence of real high speed Internet backbone traffic.

References

- [1] The Abilene Project, <http://www.internet2.edu/ucaid/abilene/>
- [2] V. Frost and B. Melamed, "Traffic Modeling for Telecommunications Networks," IEEE Communications Magazine, 32(3), pp. 70-80, March 1994.
- [3] IXIA, Traffic Generator/Analyzer, <http://www.ixiacom.com/>
- [4] W. E. Leland, M. S. Taqqu, W. Willinger, and D. V. Wilson, "On the Self-Similar Nature of Ethernet Traffic (Extended Version)," IEEE/ACM Transactions on Networking, Vol.2, No.1-15, February 1994
- [5] V. Paxson and S. Floyd, "Wide-area traffic: The failure of poisson modeling," IEEE/ACM Transactions on Networking, Vol.2, No.3, pp. 226-244, 1994.
- [6] D. Veitch, J.A Bäcker, J. Wall, and M. Roughan "ON-LINE GENERATION OF FRACTAL AND MULTIFRACTAL TRAFFIC, proceeding of PAM2000, April 2000.
- [7] K. Mituya, K. Cho, A. Kato, and J. Murai, "IP Traffic Trends in Packet Size Distribution," Internet Conference 2000, November 2000.
- [8] M. E. Crovella and A. Bestavros, "Self-Similarity in World Wide Web Traffic: Evidence and Possible Causes," in Proceedings of the 1996 ACM SIGMETRICS, pp.160-169, May 1996.
- [9] W. Willinger, M. S. Taqqu, R. Sherman, and D. Wilson, "Self-Similarity Through High-Variability: Statistical Analysis of Ethernet LAN Traffic at the Source Level," IEEE/ACM Trans. Networking, Vol.5, No.1, pp. 71-86, 1997.