

## Regular Paper

# Energy-efficient Data Collection Method with Multiple Deadlines for Wireless Sensor Networks

TATSUYA ABE<sup>1</sup> YUTAKA ARAKAWA<sup>1</sup> SHIGEAKI TAGASHIRA<sup>2,a)</sup> AKIRA FUKUDA<sup>1</sup>

Received: June 15, 2012, Accepted: December 7, 2012

**Abstract:** In this paper, we focus on a monitoring environment with wireless sensor network in which multiple mobile sink nodes traverse a given sensing field in different spatial-temporal patterns and collect various types of environmental data with different deadline constraints. For such an environment, we propose an energy-efficient data collection method that reduces intermediate transmission in multi-hop communication while meeting predetermined deadlines. The basic approach of the proposed method is to temporarily gather (or buffer) the observed data into several sensor nodes around the moving path of the mobile sink that would meet their deadlines at the next visit. Then, the buffered data is transferred to the mobile sink node when it visits the buffering nodes. We also propose a mobile sink-initiated proactive routing protocol with low cost (MIPR-LC) that efficiently constructs routes to the buffering nodes on each sensor node. Moreover, we simulate the proposed collection method and routing protocol to show their effectiveness. Our results confirm that the proposed method can gather almost all of the observed data within the deadline, while reducing the intermediate transmissions by 30%, as compared with an existing method. In addition, the MIPR-LC method can reduce the transmissions for the route construction by up to 12% when compared with a simple routing protocol.

**Keywords:** Wireless sensor network, collection method, mobile sink approach, mobile sink-initiated proactive routing protocol

## 1. Introduction

Based on recent advances in micro-electro-mechanical systems (MEMS) and wireless communication technologies, wireless sensor networks (WSNs) have emerged as a promising tool for monitoring environments in a wide range of applications [1]. A WSN is generally composed of sensor nodes for observing environment data and sink nodes for collecting the data distributed over the sensor nodes. In WSNs, collection mechanisms are often very dependent on multi-hop communication, i.e., because of limited radio ranges of sensor nodes, data transmissions between sensor-sink pairs are routed through several intermediate sensor nodes. An increase of such intermediate transmission leads to obvious power consumption concerns, especially in a large outside field without a power supply, since it is widely recognized that data transmission is responsible for a large part of the total power consumption in sensor nodes [2]. Thus, as a means to reduce the number of intermediate transmissions, a mobile sink approach has attracted considerable attention over the last decade [3], [4], [5], [6], [7], [8].

In the mobile sink approach, a mobile sink node traverses a given sensing field and collects data observed in sensor nodes when it moves close to them. This approach can achieve an energy-efficient collection of data since it does not always use

multi-hop communication, i.e., the mobile sink node can gather data directly from the sensor nodes without intermediate nodes. However, this approach increases the time delay that is required for the mobile sink node to visit the sensor nodes. To overcome the delayed collection, it is necessary for the sensor nodes to frequently use multi-hop communication in order to reach the mobile sink node, which also contributes to their large power consumption, as described above. Hence, the two objectives of realizing low power consumption and shortening the delay time appeared to be mutually exclusive during the collection of the observation data.

In this paper, we assume a monitoring environment with WSN that requires source-to-sink delay bounds according to the observation data. More concretely, in our system model, multiple mobile sink nodes exist to traverse a sensing field in a specific spatial-temporal manner and collect various kinds of environment data with different deadline constraints. For such an environment, we propose an energy-efficient data collection method that reduces the number of intermediate transmissions in multi-hop communication while meeting the delay bounds. The basic approach of the proposed method is to temporarily gather (or buffer) the observed data into several sensor nodes that exist around the moving path of the mobile sink node. The buffered data is then transferred to the mobile sink node when it visits the buffering nodes. In this paper, the buffering nodes that exist around the moving path of a mobile sink node are called mobile sink-path neighbor (MN) nodes for the mobile sink node. In addition, an MN node is said to be the shortest if it is the nearest one among

<sup>1</sup> Graduate School/Faculty of Information Science and Electrical Engineering, Kyushu University, Fukuoka 819-0395, Japan

<sup>2</sup> Faculty of Informatics, Kansai University, Takatsuki, Osaka 569-1095, Japan

<sup>a)</sup> shige@res.kutc.kansai-u.ac.jp

all the MN nodes. For these MN nodes, the proposed method uses sensor nodes that would meet the deadline at the next visit of their mobile sink node. In addition, we also propose a mobile sink-initiated proactive routing protocol with low cost (MIPR-LC) that efficiently constructs routes to the MN nodes on each sensor node, i.e., the routing table contains routes from the sensor node to the shortest MN nodes for all the mobile sink nodes.

Moreover, we evaluate the proposed collection method and routing protocol by performing simulation to show their effectiveness. As a result, we confirm that the mobile sink nodes can gather almost all of the observation data within the required deadline while reducing the number of intermediate transmissions by 30%, as compared with an existing method, and the MIPR-LC method can reduce the transmissions for the route construction by up to 12% over a simple routing protocol.

The paper is organized as follows. Section 2 describes the system model. Section 3 discusses related work. Section 4 presents the proposed collection method considering the data deadline and the energy-efficient routing protocols. Section 5 presents the simulation results. Section 6 concludes this paper.

## 2. System Model

In this section, we show the system model used in this paper. In our model, multiple mobile sink nodes traverse a given sensing field in different spatial-temporal patterns and gather various kinds of observation data with different deadline constraints. For a typical application, we assume an environmental monitoring system for farming using WSNs with mobile sink nodes, for which various data such as temperature, humidity, and sunlight are collected for the primary purpose of monitoring crop growth. Next, we explain the details of sensor nodes, mobile sink nodes, environmental data, and performance metrics.

Many homogeneous sensor nodes are deployed in the sensing field. A sensor node is static and battery powered. In addition, a sensor node periodically generates observation data that are then stored into its own local buffer that is sufficiently large (in terms of capacity) to store data until the next visit of a mobile sink node. Furthermore, two sensor nodes can directly communicate if they are within each other's radio range. Otherwise, the communication is realized through several intermediate sensor nodes, i.e., it uses multi-hop communication.

Multiple mobile sink nodes exist in the sensing field. In farm environments, there are multiple mobile elements such as farmers, farm tractors and so on. These elements can be regarded as mobile sink nodes. Each mobile sink node is uncontrollable and acts with different spatial-temporal activity pattern, i.e., we assume that mobile sink nodes go around the field multiple times to do some agricultural tasks as daily routine, such as field watering, spread of pesticide, observation of crops, and so on, and to take rests sometimes during the tasks. These tasks would be periodically carried out and the moving paths could be limited to traversable farm roads. Thus, we define the pattern as periodic with a given period and moving path. Mobile sink nodes move while broadcasting beacons at fixed intervals and gather data from the beacon-received sensor nodes.

A sensor node measures different kinds of environmental data.

These data are gathered by the mobile sink nodes. Then, the mobile sink nodes immediately transmit the collected data to a control center over a mobile phone network such as 3G or WiMAX. In addition, the monitoring system for farming requires source-to-sink delay bounds according to the observation data. For example, in the case of data logging, we consider that there are no problems even if the delay time of the collection is approximately one day. However, in the case of mechanical controls (e.g., taking effective countermeasures against cold wind damage, frost damage, and so on, based on results of the gathered data), the deadline of the data must be set to approximately one hour. Thus, it handles various kinds of environmental data with different deadline constraints. In this paper, the delay time is the time that elapses from the instant a sensor node measures data to the instant at which a mobile sink node receives the data.

Finally, we describe two performance metrics for collection methods in our system model:

**Energy consumption:** Energy consumption is an important performance metric in data collection. The network lifetime of the WSNs can be drastically extended by realizing an energy-efficient collection method. The energy consumption of a sensor node is mainly dependent on the number of data transmissions, including intermediate transmissions, which are required for the multi-hop communication and message propagation for routing construction. Thus, increasing the energy efficiency of a data collection method leads to fewer data transmissions for the collection of data.

**Delay time:** Another performance metric is the delay time for data collection. The delay time occurs owing to the nature of the mobile sink approach. The delay time is dependent on the cycle period of a mobile sink node. There is no problem if the delay time for gathering the data is within the deadline.

## 3. Related Work

Over the last decade, a number of approaches have been proposed for exploiting mobile sink nodes for data collection in WSNs. From the perspective of data collection architecture, these approaches can be broadly classified into three types: mobile base station (MBS)-based approach, mobile data collector (MDC)-based approach, and rendezvous-based approach. In this section, we introduce the three approaches.

### 3.1 MBS-based and MDC-based Approaches

In the MBS-based approach, a mobile sink node gathers observation data directly from sensor nodes using multi-hop communication. In Ref. [3], the authors address the problem of determining the sojourn times on the moving path for the mobile sink node using the linear programming (LP) method in order to maximize the network lifetime, i.e., to balance the energy consumption of all of the sensor nodes required for intermediate transmissions. In Ref. [4], the authors propose a two-tier data dissemination mechanism for large-scale WSNs in which multiple mobile sink nodes are deployed in the sensing field. With this approach, sensor nodes transmit data to the nearest mobile sink node. For this MBS-based approach, the delay time is short because the data is directly delivered from the sensor nodes to the mobile sink node.

However, many sensor nodes require more frequent intermediate transmissions for the multi-hop communication. In addition, with this approach, the sensor nodes must update the route information to the mobile sink nodes by frequently propagating control messages.

With the MDC-based approach, a sensor node stores data into its own local buffer and waits for a mobile sink node to arrive within its transmission range. When the mobile sink node arrives, the sensor node transmits the stored data to the mobile sink node in a single-hop communication. In Ref. [5], the mobile sink nodes randomly traverse the sensing field to gather the data from the sensor nodes. Moreover, to minimize the energy consumed by the entire network, the authors in Ref. [6] solve a path selection problem in delay-guaranteed sensor networks by exploiting path-constrained mobile sink nodes. With the MDC-based approach, the sensor nodes can transmit data to the mobile sink nodes without the multi-hop communication. However, the delay time increases because the sensor nodes need to store the data in local buffers until visited by the mobile sink node. In addition, it cannot gather data that has been generated by sensor nodes that do not have contact with any mobile sink node. Although a controllable mobile sink node may solve this problem, the installation of such a controllable node would incur additional costs.

### 3.2 Rendezvous-based Approach

The rendezvous-based approach is a hybrid approach that combines the MBS-based and MDC-based approaches. This approach introduces several rendezvous points (i.e., MN nodes) for a mobile sink node at which data is gathered from sensor nodes through the multi-hop communication. These MN nodes then transmit the buffered data using the single-hop communication to the mobile sink node that visits them. In Ref. [7], the mobile sink nodes pass through predetermined MN nodes while collecting data. To gather data at the MN nodes, a tree structure-based collection method has been proposed. This method organizes a tree structure from a cluster node to its child sensor nodes using a routing protocol MintRoute [9]. The MintRoute protocol establishes the shortest route from the cluster node to each child. In addition, in Ref. [8], the authors assume that the mobile sink nodes can change their moving paths over time. Hence, they have proposed a data collection method that selects as the MN nodes the sensor nodes that are to be frequently contacted by the mobile sink nodes. The rendezvous-based approach improves the energy efficiency relative to that of the MBS-based approach, in the sense that it reduces the number of intermediate transmissions for the multi-hop communication. Furthermore, it can also reduce the delay time relative to that of the MDC-based approach.

Our proposed approach can be considered to be a rendezvous-based approach. Although the existing rendezvous-based approaches do not consider the data collection with a deadline, in this paper, however, we assume that observation data has a deadline time according to its type, and multiple mobile sink nodes with different cycle periods exist in the sensing field. For such a model, we need an energy-efficient collection method to meet the deadline for gathering the sensing data.

## 4. Proposed Collection Method

In this section, we propose an energy-efficient data collection method that reduces the number of intermediate transmissions in the multi-hop communication while meeting the deadline for an observation data. Moreover, we propose the MIPR-LC protocol used in the proposed collection method to efficiently construct the routing paths for the collection on each sensor node.

### 4.1 Data Collection

The basic approach of the proposed method is also to buffer the observed data into several MN nodes. The buffered data is then transferred to the mobile sink node when it visits the MN nodes.

We describe the concrete steps in the proposed method as follows;

- (1) A sensor node observes the environmental data with a deadline.
- (2) The sensor node identifies MN nodes that would meet the deadline at the next visit of their mobile sink node. The identification is based on predicted cycle periods recorded in its routing table.
- (3) If there are no MN nodes that meet the deadline, the sensor node directly transfers the data to the mobile sink node using the MBS-based approach.
- (4) Otherwise, the sensor node finds the nearest MN node out of all discovered ones to reduce the power consumption. Then, the sensor node transfers the observation data to the nearest MN node using the multi-hop communication. If there are multiple MN nodes that are reachable in the same number of hops, the sensor node selects the MN node with the shortest cycle period.
- (5) The MN node transfers the data to the mobile sink node when it visits the MN node.

As shown in step 3, the proposed method works effectively only if there is at least one mobile sink node that meets the deadline, i.e., the cycle period of the mobile sink node is shorter than the deadline.

Each MN node stores the contact time in its own memory when it contacts with the mobile sink node and then predicts the cycle period from the stored contact times. This is a naive prediction method because it is difficult to adopt a complex algorithm which needs huge learning information and calculations for the severe restrictions of the sensor node's resources. Here, if a MN node  $D$  stores the last  $n$  contact times in its own memory and  $k$ -th contact time is represented as  $T_k$ , the predicted cycle period  $P_D$  is defined as the following equation.

$$P_D = \frac{1}{n} \sum_{k=0}^{n-1} (T_{k+1} - T_k) \quad (1)$$

**Figure 1** shows an example of the proposed collection method. In this example, we assume that there are two mobile sink nodes: mobile sink node  $M1$  with cycle period 600 s and mobile sink node  $M2$  with cycle period 200 s. The predicted cycle periods  $P_{D1}$  and  $P_{D2}$  are 600 s and 200 s, respectively. Furthermore, a sensor node  $S$  transmits data with a *deadline*. In the proposed method,  $S$  identifies MN nodes that would meet the deadline us-

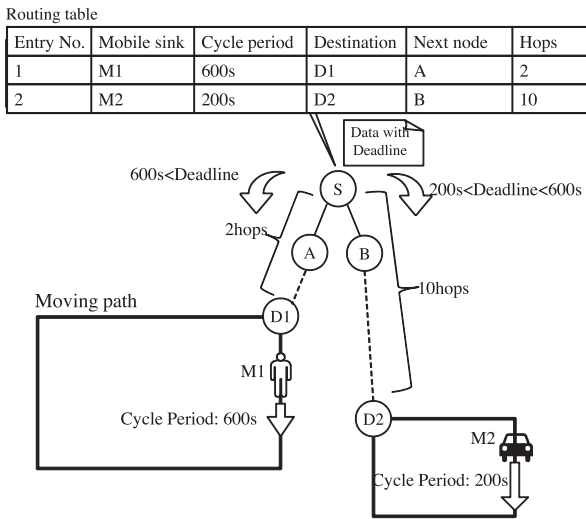

Fig. 1 An overview of the proposed method.

ing the predicted cycle periods of its routing table, and then uses the shortest MN node out of all identified ones; For example, in Fig. 1, if the *deadline* is longer than 600 s, S transmits data to A. The destination node of the transmission is D1, which is reachable in a small number of hops (i.e., 2 hops). This leads to the reduction of the retransmissions for the multi-hop communication. If the *deadline* is shorter than 600 s and longer than 200 s, S transmits data to B bound for D2. Although this selection needs a large number of hops (i.e., 10 hops), it can meet the deadline.

4.2 Route Construction

To realize the proposed collection method described in the previous section, each sensor node has to construct routes to the shortest MN node for each mobile sink node. This routing construction also leads to obvious power consumption concerns. To construct the routes, in this study, we propose two routing protocols: MIPR and MIPR-LC. The MIPR-LC method improves the MIPR method by reducing the routing cost required for constructing routing tables used in the MIPR method.

4.2.1 MIPR

The MIPR method is a proactive routing protocol that is initiated by a mobile sink node, i.e., the traversing mobile sink node periodically transmits trigger messages to one-hop neighbor sensor nodes (i.e., MN nodes). The received MN nodes broadcast control messages to the whole sensor network by employing flooding-based communication. More detailed steps in the route construction are shown below.

- (1) A mobile sink node sends trigger messages to neighbor sensor nodes while traversing the given sensing field, i.e., the message can be received by the sensor nodes that exist within its single-hop communication range.
- (2) The received sensor nodes recognize themselves as the MN nodes and broadcast a control message to all the sensor nodes. This control message includes predicted cycle period  $T_{predict}$  for the contacted mobile sink node.
- (3) Upon receiving the control message, each sensor node constructs the route to the source node of the message using the distance vector algorithm.

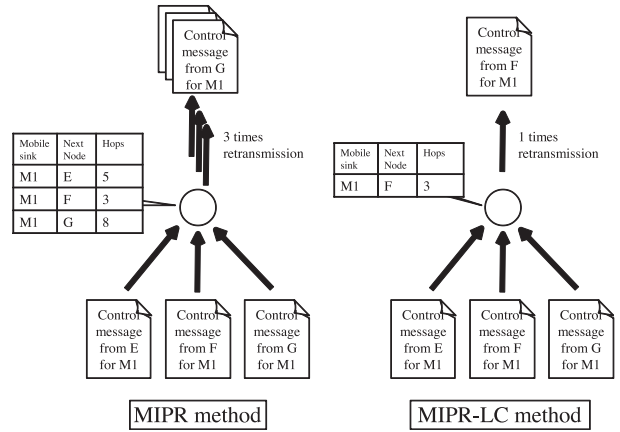

Fig. 2 Propagation for control messages.

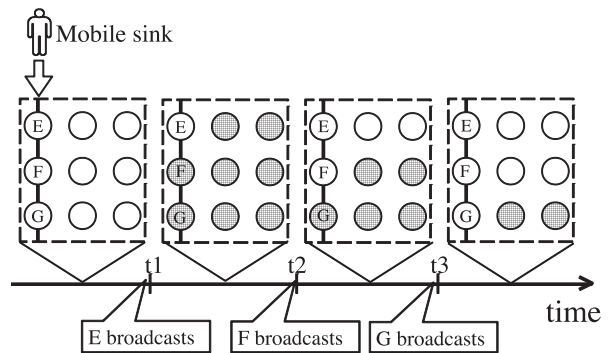

Fig. 3 Propagation region.

- (4) Each sensor node can construct routes to all MN nodes for the mobile sink node because all MN nodes broadcast the control messages. The sensor node therefore selects the nearest MN node from all of the MN ones.
- (5) The above procedure is repeated for all of the mobile sink nodes. As a result, each sensor node can construct routes to the shortest MN node for each mobile sink node.

The mobile sink node assigns a sequence number to a trigger message and reconstructs routes by incrementing the sequence number at regular intervals. Thus, control messages are assigned the same sequence number as the trigger message. Each sensor node constructs routes by the latest route information.

4.2.2 MIPR-LC

In the MIPR method, a routing table is constructed for each sensor node by employing flooding-based broadcasts. The broadcasts increase the energy consumption of the sensor nodes owing to repeated retransmissions of control messages in the sensor nodes. The goal of the MIPR-LC method is to reduce the retransmissions. In the MIPR method, all MN nodes broadcast control messages and the received sensor nodes retransmit the messages (on the left side in Fig. 2). However, in the proposed collection method, it is sufficient that each sensor node constructs the route to the shortest MN node. Therefore, in the MIPR-LC method, a sensor node retransmits the message only when the coming path length for the received control message is the shortest (on the right side in Fig. 2).

We now consider the trigger timing when a mobile sink node sends a trigger message. Figure 3 shows the transition of the propagation region in the MIPR-LC method in chronological or-

der. In this figure, sensor nodes  $E$ ,  $F$ , and  $G$  are MN nodes for the same mobile sink node.  $E$ ,  $F$ , and  $G$  broadcast a control message at  $t_1$ ,  $t_2$  and  $t_3$ , respectively. In this figure, sensor nodes that have retransmitted a control message by the broadcast are marked as meshing. It can be seen that the propagation region changes depending on the sending order, i.e., the propagation region is the narrowest when  $G$  sends the last control message. Thus, we consider the trigger timing of control messages to minimize the propagation region.

## 5. Performance Evaluation

In this section, we evaluate the proposed collection method by performing simulation. The collection method and routing protocol proposed in this paper are implemented on the network simulator platform QualNet version 5.0.1 [10].

### 5.1 Comparison of Three Collection Methods

First, we evaluate the proposed collection method. In this simulation, we measure the number of data that has been stored within the deadline and the energy consumption of the sensor nodes. We compare the results of three methods: our proposed data collection method, a rendezvous-based approach that always uses the shortest MN nodes regardless of delay bound constraints (called RAS hereafter), and a rendezvous-based approach that always uses the MN nodes for the fastest mobile sink nodes regardless of energy consumption as was proposed in Ref. [8] (called RAF hereafter). Note that in this simulation, the route for each sensor node is constructed by the same method.

The simulation parameters used in our experiments are summarized in **Table 1**. Furthermore, as shown in **Fig. 4**,  $10 \times 20$  sensor nodes are placed at fixed intervals of 150 m. Each sensor node can communicate with its neighbor nodes. In addition, the sensor nodes generate two sets of data ( $A$ ,  $B$ ) with different deadlines. In this simulation, two mobile sink nodes are positioned:

**Table 1** Simulation parameters.

Parameter	Value
Simulation time (s)	3,600
Number of mobile sink nodes	2
Cycle period of mobile sink node $A$ (s)	200
Cycle period of mobile sink node $B$ (s)	600
Data generation rate (packets/h)	12
Packet size (bytes)	100
Deadline of data $A$ (s)	300
Deadline of data $B$ (s)	700
TX rate (Mbps)	1
TX power (mW)	100
RX power (mW)	130

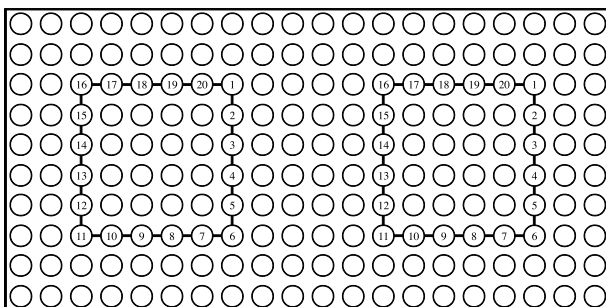

**Fig. 4** Simulation environment for evaluating collection methods.

mobile sink node  $A$  with a short cycle period is placed on the left side of the field, and mobile sink node  $B$  with a long cycle period is placed on the right side. Each mobile sink node traverses the field at a constant speed along with the heavy line of Fig. 4. In addition, we consider a farm truck as mobile sink node  $A$  and a farm tractor as mobile sink node  $B$ . Thus, we set 15 m/s to the moving speed of  $A$  (i.e., cycle period of 200 s) and 5 m/s to that of  $B$  (i.e., cycle period of 600 s).

In this simulation, we assume that the wireless sensor network is based on IEEE802.11b (WiFi) wireless communication. In addition, we used a generic radio energy model which is defined in Ref. [10]. Thus, we set 100 mW and 130 mW to Tx power and Rx power, respectively.

As shown in Table 1, as the deadlines of the data, we set longer values than the cycle period of mobile sink node  $A$  (i.e., 200 s), because the proposed method works effectively only if there is at least one mobile sink node that meets the deadline. Hence, if both two deadlines are greater than the cycle period of mobile sink node  $B$  (i.e., 600 s), the behavior of the proposed method is very similar to that of the RAS method. Therefore, in order to examine the behavior of the proposed method, as one deadline we set a shorter value (300 s) than 600 s, and as the other deadline set a longer value (700 s) than 600 s.

**Table 2** shows the summarized results of the measurements. The number of data generated, the number of data collected, the data collection ratio, the number of data collected within the deadline, the data collection ratio within the deadline, and total energy consumption in transmission are represented as  $N_{gen}$ ,  $N_{agg}$ ,  $R_{agg}(= N_{agg}/N_{gen})$ ,  $N_{aggwd}$ ,  $R_{aggwd}(= N_{aggwd}/N_{gen})$ , and  $P_{total}$ , respectively. From the table,  $R_{agg}$  for all the collection methods is over 94%. Note that the reason why  $R_{agg}$  does not reach 100% is because transmissions are lost due to packet collision and radio noise, and the buffered data for the mobile sink node with a longer cycle period still remains in its MN node at the end of the simulation.

For  $R_{aggwd}$ , RAS is the worst among the three collection methods. The collection ratio for RAS is about 80%, although it achieves the energy-saving collection. RAS always uses the shortest MN nodes as the buffering nodes regardless of the delay bounds. On the other hand, the proposed and RAF methods achieve good performance. Moreover, we can observe that the proposed method improves  $P_{total}$  by 30% compared to RAF. Thus, the proposed method can gather almost all of the observed data within the deadline while reducing  $P_{total}$  by 30% relative to that of the RAF method.

### 5.2 Impact of Mobile Sink Node's Behavioral Characteristic

Next, we examine the impact of the mobile sink's behavioral

**Table 2** Evaluation results for the proposed collection methods.

	Proposed	RAS	RAF
$N_{gen}$	2,400	2,400	2,400
$N_{agg}$	2,326	2,257	2,380
$R_{agg}$ (%)	96.9	94.0	99.1
$N_{aggwd}$	2,326	1,926	2,380
$R_{aggwd}$ (%)	96.9	80.2	99.1
$P_{total}$ (nJ)	192	114	280

**Table 3** State transition probabilities in the WWP mobility model.

	P1	P2	P3
P1	0	0.8	0.2
P2	0.7	0	0.3
P3	0.5	0.5	0

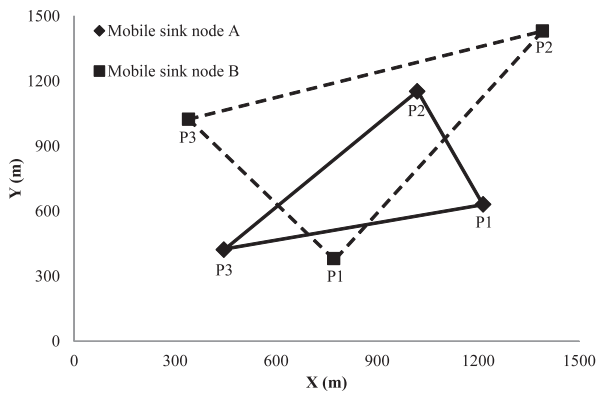
**Fig. 5** An example of anchor points for each mobile sink node.

**Table 4** Evaluation results of mobile sink node's behavioral characteristic.

	CD			WWP		
	Proposed	RAS	RAF	Proposed	RAS	RAF
$N_{gen}$	1,200	1,200	1,200	1,200	1,200	1,200
$N_{agg}$	1,115	1,082	1,142	1,078	1,046	1,136
$R_{agg}$ (%)	92.9	90.2	95.2	89.8	87.2	94.7
$N_{aggwd}$	1,083	909	1,105	984	905	1,054
$R_{aggwd}$ (%)	90.3	75.8	92.1	82.0	75.4	87.8
$P_{total}$ (nJ)	402	303	458	297	286	373

characteristic to the collection performance. In this experiment, 100 sensor nodes are randomly placed in the  $1,500\text{ m} \times 1,500\text{ m}$  sensing field. The range of radio communication for the sensor nodes is 180m. Each mobile sink node traverses three anchor points ( $P1, P2, P3$ ) that are randomly determined in advance under two mobility models: the constant direction (CD) mobility model and the WWP mobility model [12]. The WWP mobility model is a model to reproduce the mobility of humans. In the CD model, the mobile sink node traverses the anchor points in a certain constant direction. In the WWP model, the mobile sink node traverses the anchor points under the state transition probability shown in **Table 3**. **Figure 5** shows an example of anchor points for each mobile sink node. For other simulation parameters, we use the same values as that in Section 5.1.

**Table 4** shows the summarized results of the measurements. We repeated the measurements three times and averaged the results obtained. First, from the results of the CD model, the proposed method achieves  $R_{aggwd}$  of over 90% and reduces the energy consumption of the sensor nodes relative to that of the other methods. However, as compared with the result of **Table 2**,  $R_{agg}$  and  $R_{aggwd}$  decrease by about 5% for the three collection methods. This is because there are sensor nodes that do not have a connection to any MN node due to the random placement of the sensor nodes.

Next, from the results of the WWP model, the proposed method can achieve the improvement of  $R_{aggwd}$  over the RAS method and the reduction of  $P_{total}$  over the RAF method even in a more realistic situation. As compared to the CD model, however, the effectiveness of the proposed method is limited; i.e., the result of the proposed is close to that of RAS. This is because the

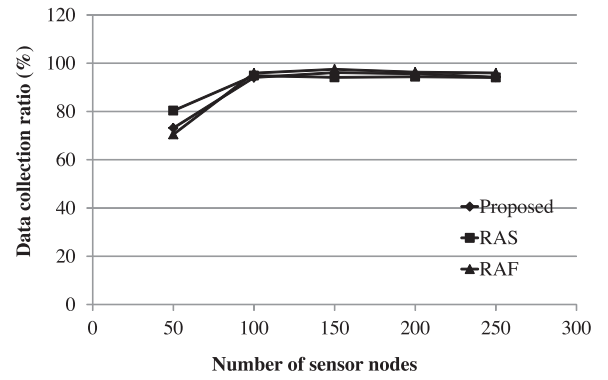
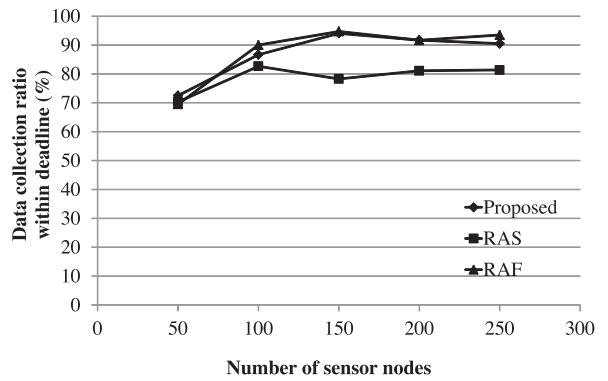
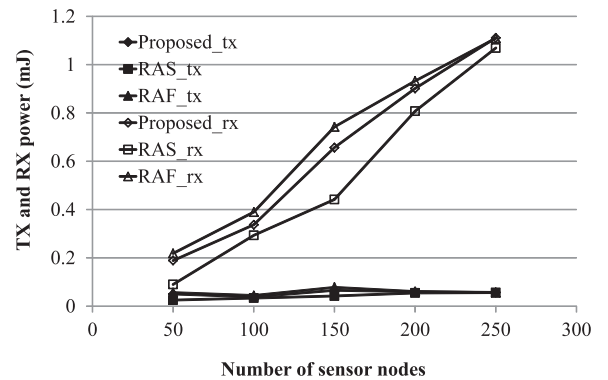
**Fig. 6** Data collection ratio as a function of sensor nodes' density.

**Fig. 7** Data collection ratio within the deadline as a function of sensor nodes' density.

**Fig. 8** Transmission and received power of sensor nodes as a function of sensor nodes' density.

proposed method incorrectly estimates the cycle periods of the mobile sink nodes due to the variation in the contact time caused by the WWP mobility model.

### 5.3 Impact of Sensor Nodes' Density

We examine the impact of sensor nodes' density to the collection performance. In this simulation, sensor nodes are randomly placed in the  $1,500\text{ m} \times 1,500\text{ m}$  sensing field while varying the number of the sensor nodes. The mobile sink nodes traverse three anchor points ( $P1, P2, P3$ ) according to the CD model. For other simulation parameters, we use the same values as that in Section 5.2.

**Figure 6**, **Fig. 7**, and **Fig. 8** shows the results for  $R_{agg}$ ,  $R_{aggwd}$ , and  $P_{total}$  as a function of sensor nodes' density in the three collection methods, respectively. We repeated the measurements three times and averaged the results obtained. First, from **Fig. 6**,

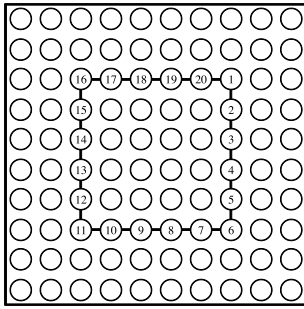

Fig. 9 Simulation environment for evaluating routing protocols.

$R_{agg}$  is less than 81% in all the collection methods when the number of sensor nodes is 50. However,  $R_{agg}$  shows a constant value of about 95% when the number of sensor nodes is over 100. This is because several sensor nodes do not have connection with any MN node when the number of sensor nodes is 50. When the number of sensor nodes is over 100, almost all of the sensor nodes have contact with at least one MN node.

Next, as shown in Fig. 7,  $R_{aggwd}$  is less than 73% in all the collection methods when the number of sensor nodes is 50. When increasing the number of the sensor nodes (i.e., over 100),  $R_{aggwd}$  of RAS shows a constant value about 80%, while the proposed and RAF methods achieve about 90%. This is because RAS cannot totally satisfy the deadline of data  $A$  due to the selection of the shortest MN nodes.

In Fig. 8, for  $P_{total}$ , TX power of sensor nodes shows a constant value of about 0.05 mJ regardless of the sensor nodes' density. On the other hand, RX power of sensor nodes shows a linear increase with the increase of the sensor nodes' density. This is because when the density increases, the number of sensor nodes within the radio range of a sensor node also increases. And thus when a sensor node transfers the data, all sensor nodes within the range receive the data and consume power. For TX power of sensor nodes, only one sensor node is selected from all the received ones and then retransmits the data. Thus, TX power shows a constant value regardless of the density.

Hence, we can observe that TX and RX powers of sensor nodes increase in the order of RAF, Proposed, and RAS regardless of sensor nodes' density.

5.4 Evaluation of Routing Protocols

Next, we evaluate the average energy consumption required for routing protocols, i.e., it depends on the number of control message retransmissions that are required to construct routes to the shortest MN nodes for all mobile sink nodes. In this simulation, as shown in Fig. 9, 10 × 10 sensor nodes and 20 MN nodes numbered from 1 to 20 are regularly placed at intervals of 150 m.

We describe our results and compare them to those obtained using the MIPR-LC method, the MIPR method, and the RIP method [11]. The RIP method is a sensor node-initiated proactive routing protocol based on the distance vector algorithm. Furthermore, in MIPR-LC, we evaluate the impact of the trigger timing on the results. More concretely, we implement the three trigger timings, (a), (b), and (c) and represent the control messages sent by each node (1, 2, 3, ..., 19, 20), as well as by every three nodes (1, 4, 7, ..., 15, 18) in a diagonal manner (1, 11, 6, 16, 2, 12, 7,

Table 5 Simulation parameters for routing protocol.

Parameter	Value
RIP version	2
Split horizon	simple

Table 6 Evaluation results for the proposed routing protocols.

	MIPR-LC			MIPR	RIP
	(a)	(b)	(c)		
$P_{tx}$ [nJ]	98	71	53	410	111
$P_{rx}$ [nJ]	521	378	292	2,191	590
$P_{total}$ [nJ]	619	449	346	2,601	701

17, ..., 10, 20), respectively.

In this experiment, each sensor node can communicate with its neighbor nodes. The simulation parameters are summarized in Table 1. In MIPR-LC and MIPR, the MN nodes transmit control messages every second. In addition, the mobile sink node assigns a sequence number to a trigger message and reconstructs routes by incrementing the sequence number at regular intervals, as described in Section 4.2.1. And then the control messages are assigned the same sequence number as the trigger message. Each sensor node constructs routes by the latest route information. In this experiment, the interval is set to 20 s. Furthermore, the routing parameters for the RIP method are shown in Table 5.

Table 6 shows the results. Transmission energy consumption, received energy consumption, and total energy consumption are represented as  $P_{tx}$ ,  $P_{rx}$ , and  $P_{total}$ , respectively. From the table, MIPR-LC improves  $P_{total}$  by 24% over MIPR. This is because the sensor nodes do not retransmit unnecessary control messages in MIPR-LC, i.e., they retransmit control messages only when the next path length is shorter than previous path lengths, as described in Section 4.2.2. Furthermore, we confirm the effect of the trigger timing on  $P_{total}$ . From the table,  $P_{total}$  of the timing MIPR-LC (c) is the lowest of all the timings. This is because in MIPR-LC (c), the sensor nodes can transmit control messages in the most spatially distributed manner, i.e., the transmissions of control messages are initiated in a diagonal order (node 1, 11, 6, 16, 2, 12, 7, 17, ..., 10, and 20) as shown in Fig. 9. The propagation region for the transmissions in MIPR-LC (c) is narrower than that in MIPR-LC (a) as described in Section 4.2.2, which leads to the reduction of the retransmissions. However, MIPR-LC (c) takes a longer time to construct routes than MIPR-LC (a), because the mobile sink node goes around the field several times in order to initiate all transmissions in the sending order of MIPR-LC (c). In addition, we can observe that MIPR-LC achieves the improvement of  $P_{total}$  by 12% over the simple proactive routing protocol RIP.

6. Conclusions

In this paper, we proposed a data collection method that reduces the number of intermediate transmissions in the multi-hop communication while meeting deadlines. In our proposed approach, the observed data with deadlines is gathered for a set of MN nodes having a mobile sink node that can meet the deadline at the next visit. More concretely, each sensor node selects a mobile sink node that meets the deadline of the observed data, which is based on a prediction of the arrival interval. The observed data is then transmitted to the shortest MN nodes that correspond to

the selected mobile sink node. In addition, we propose a MIPR-LC protocol that is required for the proposed collection method that efficiently constructs a routing table on each sensor node. As a result, we confirm that the proposed method can gather almost all of the observed data within the deadline, while reducing the intermediate transmissions by 30%, as compared with an existing method. In addition, the MIPR-LC method can reduce the transmissions for the route construction by up to 12% when compared with a simple routing protocol.

In future, we will evaluate the impact of different mobility patterns in mobile sink nodes to the performance, in order to clarify the impact of mobile sink nodes with various mobility patterns. The evaluation for different mobility patterns is one of the most important issues in the performance evaluation of the proposed scheme, e.g., different state transition probabilities in the WWP model, different numbers of destinations, and different moving speeds. In addition, the proposed method is designed for periodic mobility. The periodic mobility is very similar to controlled mobility. However, we consider the periodic mobility is slightly different from the controlled mobility, because we could not exactly estimate cycle periods in our assumed periodic mobility as compared with the controlled mobility. Therefore, we have to make the proposed technique more tolerant in unpredictable mobile sink's behavior. Furthermore, we will study a data collection method that can reduce the intermediate transmission even if the deadline is longer than the shortest cycle period of mobile sink nodes. Finally, we will examine in more detail the trigger timing for control messages and conduct additional experiments in a more realistic environment including several experiments for evaluating the routing protocol in the network topology of Fig. 4.

**Acknowledgments** The work described in this paper was partially supported by the Strategic Information and Communications R&D Promotion Programme (SCOPE).

## References

- [1] Akyildiz, I., Su, W., Sankarasubramniam, Y. and Cayirci, E.: A Survey on Sensor Networks, *IEEE Communication Magazine*, No.8, pp.102–114 (2002).
- [2] Estrin, D., Sayeed, A. and Srivastava, M.: Wireless Sensor Networks, Tutorial at the Eighth ACM International Conference on Mobile Computing and Networking (2002).
- [3] Wang, Z.M., Basagni, S., Melachrinoudis, E. and Petrioli, C.: Exploiting Sink Mobility for Maximizing Sensor Networks Lifetime, *Proc. 38th Annual Hawaii International Conference on System Sciences*, p.287 (2005).
- [4] Luo, H., Ye, F., Cheng, J., Lu, S. and Zhang, L.: TTDD: Two-Tier Data Dissemination in Large-Scale Wireless Sensor Networks, *Elsevier/ACM Wireless Networks*, Vol.11, No.1-2, pp.161–175 (2005).
- [5] Jain, S., Shah, R.C., Roy, S. and Brunette, W.: Exploiting Mobility for Energy Efficient Data Collection in Wireless Sensor Networks, *IEEE Workshop on Modeling and Optimization in Mobile Ad hoc and Wireless Networks*, Vol.11, No.3, pp.327–339 (2006).
- [6] Gao, S. and Zhang, H.: Energy Efficient Path-constrained Sink Navigation in Delay-guaranteed Wireless Sensor Networks, *Journal of Networks*, Vol.5, No.6, pp.658–665 (2010).
- [7] Luo, J., Panchard, J., Piorkowski, M., Grossglauser, M. and Hubaux, J.P.: MobiRoute: Routing towards a Mobile Sink for Improving Lifetime in Sensor Networks, *Proc. IEEE Int. Conf. on Distributed Computing in Sensor Systems*, pp.10–11 (2006).
- [8] Yamamoto, A., Kondo, S., Kanzaki, A., Hara, T. and Nishio, S.: On Selection of Data Forwarding Destinations Based on Status of Connection with Mobile Sinks in Wireless Sensor Networks, *DICOMO 2011*, Vol.2011, No.1, pp.878–885 (2011).
- [9] Woo, A., Tong, T. and Culler, D.: Taming the Underlying Challenges of Reliable Multihop Routing in Sensor Networks, *Proc. Int. Conf. on Embedded Networked Sensor Systems*, pp.14–27 (2003).
- [10] Scalable Network Technologies, Inc.: *QualNet Simulator*, available from (<http://www.scalablenetworks.com/>).
- [11] Hedrick, C.: Routing Information Protocol, RFC 1058 (June 1988).
- [12] Hsu, W., Merchant, K., Shu, H., Hsu, C. and Helmy, A.: Weighted Waypoint Mobility Model and its Impact on Ad Hoc Networks, *ACM Mobile Computer Communications Review*, pp.59–63 (Jan. 2005).



**Tatsuya Abe** received his B.Eng. and M.Eng. degrees from Kyushu University in 2010 and 2012, respectively. His current research interests include wireless sensor networks.



**Yutaka Arakawa** was born in 1977. He received his B.E., M.E., and Ph.D. degrees, from Keio University, Japan, in 2001, 2003, and 2006, respectively. He was an assistant professor at Keio University in 2006, and became an assistant professor at Kyushu University in 2009. Additionally, he worked as a visiting researcher at ENSEIHT (France) in 2011, and at DFKI (Germany) in 2012. His current research interest is social-data mining, network application, and location-based information systems. He received Best Paper Award of APCC/COIN2008, Best Paper Award of IPSJ SIG-MBL in 2009 and 2010, Excellent Paper Award of IPSJ DICOMO2010, Best Presentation Award of IPSJ DICOMO2010, IPSJ Yamashita SIG Research Award in 2011, 24th Hiroshi Ando Memorial Award in 2011, Best Poster Award of DPS workshop in 2011, Best Paper Award of DPS workshop in 2012. He is a member of IEEE of USA, IEICE of Japan, and IPSJ.



**Shigeaki Tagashira** received his B.Eng. degree from Ryukoku University in 1996; and the M.Eng. and D.Eng. degrees in information science from Nara Institute of Science and Technology (NAIST) in 1998 and 2000, respectively. He worked as a research associate at Hiroshima University from 2000 to 2007. In 2007, he joined Kyushu University, as a project associate professor. Since 2012 he has been an associate professor at Kansai University. His current research interests include ubiquitous/mobile computing and system software. He is a member of IEICE and IEEE.





**Akira Fukuda** received his B.Eng, M.Eng, and Ph.D. degrees in computer science and communication engineering from Kyushu University, Japan, in 1977, 1979, and 1985, respectively. From 1977 to 1981, he worked for the Nippon Telegraph and Telephone Corporation, where he engaged in research on the

performance evaluation of computer systems and the queueing theory. From 1981 to 1991 and from 1991 to 1993, he worked for the Department of Information Systems and the Department of Computer Science and Communication Engineering, Kyushu University, Japan, respectively. In 1994, he joined Nara Institute of Science and Technology, Japan, as a professor. Since 2001 and 2008, he has been a professor of the Graduate School of Information Science and Electrical Engineering, and the director of System LSI Research Center, Kyushu University, Japan, respectively. His research interests include embedded systems, ubiquitous computing, system software (operating systems, compiler, and run-time systems), parallel and distributed systems, and performance evaluation. He received the 1990 IPSJ (Information Society of Japan) Research Award and the 1993 IPSJ Best Author Award. He is a member of ACM, IEEE Computer Society, IEICE, and the Operations Research Society of Japan.