

Periodic Broadcast Timing Reservation Multiple Access for Inter-vehicle Communication

KENJI ITO,^{†1} NORIYOSHI SUZUKI,^{†1} SATOSHI MAKIDO^{†1}
and HIROAKI HAYASHI^{†1}

The present study investigates a Medium Access Control (MAC) protocol for reliable inter-vehicle communications (IVC) to support safe driving with the goal of reducing road traffic accidents. A number of studies have evaluated the performance of the Carrier Sense Multiple Access with Collision Avoidance (CSMA/CA) protocol. However, the communication quality provided by the CSMA/CA protocol is seriously degraded by the hidden terminal problem in IVC. Therefore, we propose a new MAC protocol, referred to as Periodic Broadcast-Timing Reservation Multiple Access (PB-TRMA), which can autonomously control transmission timing and avoid packet collisions by enhancing the Network Allocation Vector (NAV) for periodic broadcast communications. The simulation results show that the proposed protocol can resolve the hidden terminal problem and mitigate data packet collisions. Moreover, the behavior of PB-TRMA is similar to that of Time-Division Multiple Access (TDMA). In addition, we show that two procedures, namely, packet collision retrieval and hidden terminal detection, are essential ingredients in PB-TRMA in order to achieve high quality performance.

1. Introduction

Active safety technologies to reduce traffic deaths and injuries, such as vehicle safety communications (VSC), have been increasingly investigated in recent years^{1)–3)}. These technologies include two types of driving support system: *autonomous-detection type* and *inter-vehicle communication (IVC) type*, both of which can help to prevent collisions.

Radars and cameras installed on vehicles help to prevent collisions with forward obstacles through an autonomous-detection type driving support system, which is a completely self-contained system. Several such systems are currently

in commercial production. However, traffic scenarios without line-of-sight (e.g., a collision when making a turn collisions at an intersection) have a high potential to cause death or serious injury as a result of road traffic accidents. The autonomous-detection type driving support system is ineffective in environments with obstacles that are out of the line-of-sight.

On the other hand, collision avoidance warning systems using IVC are highly anticipated. In June of 2007, the Japanese Ministry of Internal Affairs and Communications designated the 700 MHz band with a bandwidth of 10 MHz for use in IVC systems, and automobile manufacturers are accelerating research and development for these systems. In the fourth phase of the Advanced Safety Vehicle project (ASV-4), which has been undertaken by the Japanese Ministry of Land, Infrastructure, Transport and Tourism³⁾, positional and directional information obtained by Global Positioning System (GPS) and velocity information are periodically exchanged between vehicles at intersections or hidden driveways by broadcast communications (see **Fig. 1**). In this phase, warnings are generated to inform drivers of a possible collision.

In these systems, it is essential for multiple vehicles to be able to exchange data with low-delay and high reliability over autonomous distributed control networks, even in urban environments. A number of studies have evaluated the performance of IVC using the Carrier Sense Multiple Access with Collision Avoidance (CSMA/CA) protocol⁴⁾. However, the communication quality is seriously degraded by the hidden terminal problem in IVC⁵⁾.

Several MAC protocols have been proposed in an attempt to address the hidden terminal problem^{6)–15)}. Specifically, in Refs. 6) and 7), request-to-send and clear-to-send (RTS/CTS) dialogue mitigates data packet collisions by exchanging short RTS/CTS packets before data packet transmission. However, this dialogue cannot be used in broadcast communication.

A broadcast protocol based on collision prevention policy has been proposed in Ref. 8). The protocol enhances RTS/CTS exchange to broadcast communications by using the risk degree of a hidden terminal. However, periodic communication is not considered in Ref. 8). Also, the coverage of the protocol is a static network or semi-static one. Therefore, performance in the network, where terminals with mobility are included such as vehicular communications, has not been evaluated.

^{†1} Toyota Central Research and Development Laboratories, Inc.

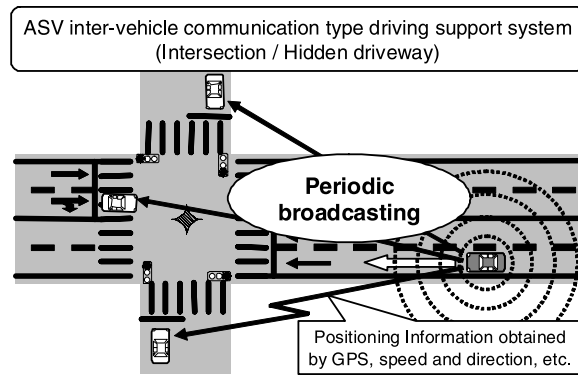

Fig. 1 Inter-vehicle communication system for safety.

Although Busy Tone Multiple Access (BTMA)⁹⁾ has also been introduced to alleviate the hidden terminal problem, it does not solve the hidden terminal problem in systems that do not have a single base station. Among recently proposed MAC protocols, Dual BTMA (DBTMA)¹⁰⁾ solves the hidden terminal problem in an ad hoc network. However, DBTMA requires that the frequency channel be divided into a data channel and two busy tone channels.

The present paper studies the systems in which vehicles need to transmit periodically by broadcast communications. Each terminal must be able to transmit at least once per time period. Therefore, a Time Division Multiple Access (TDMA) frame structure appears to be a well-adapted scheme. Several TDMA protocols for addressing the hidden terminal problem have been proposed in Refs. 11)–15). However, in these protocols, timing synchronization must be autonomously ensured between all mobile stations (e.g., slot or frame synchronization), and, in general, establishing timing synchronization without key stations, such as access-point stations or base stations, appears extremely difficult. Therefore, we propose a new MAC protocol, referred to as Periodic Broadcast-Timing Reservation Multiple Access (PB-TRMA).

PB-TRMA can autonomously control transmission timing and solve the hidden terminal problem by enhancing the Network Allocation Vector (NAV) to periodic broadcast communications. The proposed protocol uses one frequency channel

and does not need to autonomously establish slot synchronization between all vehicles. The simulation results show that PB-TRMA can avoid data packet collisions and that it behaves similarly to TDMA. In addition, we confirm that two procedures, namely, packet collision retrieval and hidden terminal detection, are essential to PB-TRMA in order to achieve high quality performance, e.g., high packet success probability.

The remainder of the present paper is organized as follows. In Section 2, we present the details of the PB-TRMA protocol. Section 3 explains the simulation model and describes the simulation specifications and performance measure. Section 4 presents the simulation results and a discussion of the features of PB-TRMA. Finally, Section 5 presents our conclusions.

2. PB-TRMA Protocol

In this section, we describe the proposed Periodic Broadcast-Timing Reservation Multiple Access (PB-TRMA) protocol.

2.1 Basic Concept

The basic access scheme of the PB-TRMA protocol is CSMA/CA. Thus, in a carrier sense area, the protocol can avoid data packet collisions by using a carrier sense mechanism. After each mobile terminal receives a data packet and T_{rep} time passes, the mobile terminal transmits a *communication result (CR) signal*, which notifies a number of surrounding mobile terminals of the correct reception of a data packet or detection of packet collisions, while neglecting the carrier sense mechanism. Each terminal then transmits the CR signal earlier than the other data packets in order to decide the communication result corresponding to a transmitted data packet. Therefore, we use Inter Frame Space (IFS) based priority mechanisms and set T_{rep} to Short IFS (SIFS), which has the highest priority.

Figure 2 illustrates the basic concept of PB-TRMA. In the PB-TRMA protocol, the following three packets are transmitted:

- DATA: packet composed of a preamble and data payload,
- BUSY: CR signal indicating the correct reception of a DATA packet,
- COLL: CR signal indicating that a DATA packet collision has occurred.

The CR signals cannot be received correctly, because they are received almost

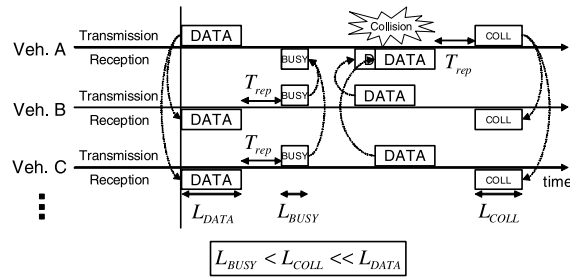

Fig. 2 Basic concept of PB-TRMA.

simultaneously from several vehicles that received DATA. Therefore, each vehicle discriminates between BUSY and COLL by setting different lengths for these signals in the time domain:

$$L_{BUSY} < L_{COLL} \ll L_{DATA}, \tag{1}$$

where L_{BUSY} , L_{COLL} , and L_{DATA} denote the signal length in the time domain of BUSY, COLL, and DATA, respectively. In addition, the transmission timing of DATA is controlled by setting NAV based on the reception of the CR signal as one of the features of PB-TRMA. NAV is a virtual carrier sense mechanism. Therefore, if the vehicle sets NAV for a certain period, then the vehicle refrains from transmission of DATA during this period. Note that BUSY and COLL are transmitted independent of NAV. In the next subsection, we introduce the method of transmission timing control by setting NAV.

2.2 Collision Retrieval Method

PB-TRMA supposes that each vehicle transmits DATA periodically by broadcast. Therefore, once a collision occurs between transmitted DATA, DATA packet collision occurs continuously unless the subsequent transmission timing is changed autonomously.

Figure 3 shows the NAV setting method for the case in which DATA packet collisions occur. In this figure, there are three vehicles, A, B, and C, and the ellipses denote the communication area of each vehicle. Thus, vehicles A and C are hidden terminals with respect to vehicle B. When DATA packets of vehicles A and C collide, vehicle B broadcasts COLL after T_{rep} time passes. Vehicles A and C receive COLL in $T_{collect}$ time, which is the reception time for the collection

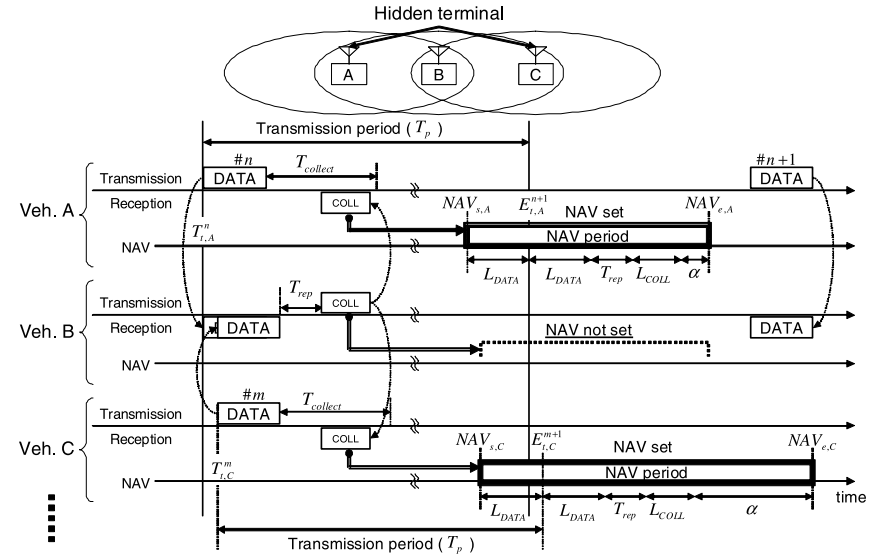

Fig. 3 Packet collision retrieval method in PB-TRMA.

of the CR signal, after transmitting DATA. Vehicles A and C then set NAV for the following period $[NAV_{s,j}, NAV_{e,j}]$:

$$E_{t,j}^{n+1} = T_{t,j}^n + T_p, \tag{2}$$

$$NAV_{s,j} = E_{t,j}^{n+1} - L_{DATA}, \tag{3}$$

$$NAV_{e,j} = E_{t,j}^{n+1} + L_{DATA} + T_{rep} + L_{COLL} + \alpha, \tag{4}$$

where $NAV_{s,j}$ and $NAV_{e,j}$ denote the start time and the finish time, respectively, of the NAV set period of the vehicle j (i.e., $j = A, C$). In addition, $T_{t,j}^n$, T_p , and $E_{t,j}^{n+1}$ denote the transmission start time of the n th DATA of vehicle j , the transmission period, and the estimated transmission start time of the $(n + 1)$ th DATA of vehicle j , respectively. In order to avoid packet collision of subsequent DATA, the finish time of the NAV set period is decided by a random value, α , which denotes a uniform random number in the time period $[0, T_p]$.

In addition, in order to increase the opportunities for DATA transmission, vehicle B does not set NAV, because vehicles A and C change the transmission

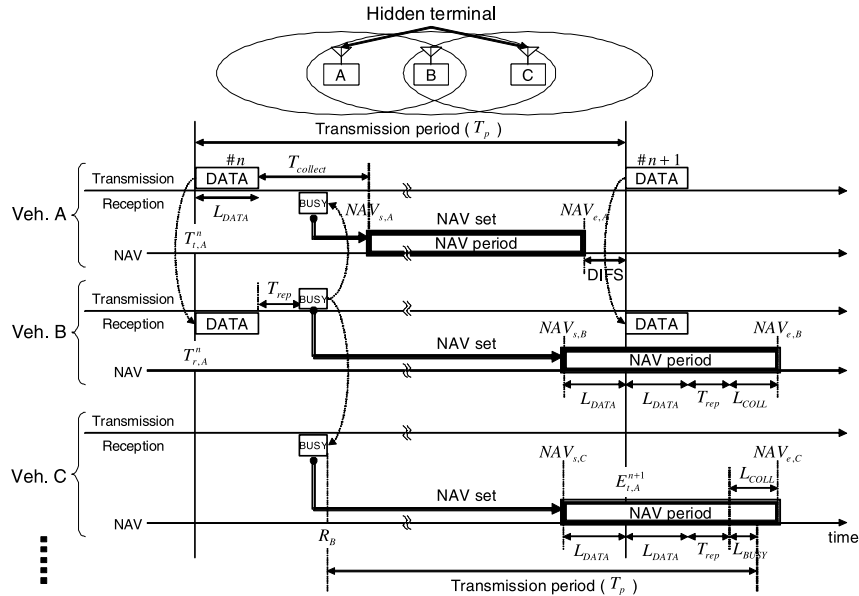

Fig. 4 Hidden terminal detection and packet collision avoidance method.

timing of the subsequent DATA by setting NAV.

2.3 Hidden Terminal Detection and Collision Avoidance Method

Figure 4 shows the NAV setting method involved in hidden terminal detection. In this figure, the positions of three vehicles and the relationship among the hidden terminals are the same as in Fig. 3. Vehicle B transmits BUSY by broadcast after receiving DATA from vehicle A. Then, vehicle C can detect the hidden terminal, vehicle A in Fig. 4, by receiving BUSY from vehicle B. In PB-TRMA, all vehicles transmit DATA periodically. Therefore, in order to avoid colliding with the subsequent DATA packet of vehicle A, vehicle C sets NAV during the following period of the subsequent transmission timing of vehicle A:

$$E_{t,A}^{n+1} = R_B + T_p - L_{BUSY} - T_{rep} - L_{DATA}, \quad (5)$$

$$NAV_{s,C} = E_{t,A}^{n+1} - L_{DATA}, \quad (6)$$

$$NAV_{e,C} = E_{t,A}^{n+1} + L_{DATA} + T_{rep} + L_{COLL}, \quad (7)$$

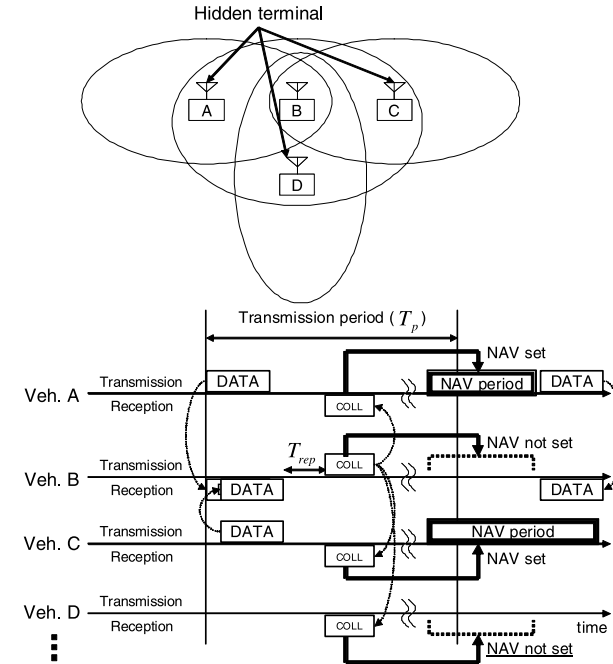

Fig. 5 Hidden terminal detection by receiving COLL.

where R_B represents the received time of BUSY. On the other hand, vehicle B sets NAV during the following period and reserves the subsequent transmission timing for vehicle A, using the received start time of the n th DATA of vehicle A, $T_{r,A}^n$,

$$NAV_{s,B} = T_{r,A}^n + T_p - L_{DATA}, \quad (8)$$

$$NAV_{e,B} = T_{r,A}^n + T_p + L_{DATA} + T_{rep} + L_{COLL}. \quad (9)$$

Then, vehicle A receives BUSY in time $T_{collect}$ and sets NAV for the period from the received time of BUSY to the subsequent transmission timing of DATA, $[NAV_{s,A}, NAV_{e,A}]$,

$$NAV_{s,A} = T_{r,A}^n + L_{DATA} + T_{collect}, \quad (10)$$

$$NAV_{e,A} = T_{r,A}^n + T_p - DIFS, \quad (11)$$

where $DIFS$ represents Distributed IFS defined in Distributed Coordination

Table 1 Simulation Specifications.

| item | value |
|-------------------------------|-------------------|
| Transmission period (T_p) | 25 ms |
| Communication area | 100 m |
| Carrier sense area | 100 m |
| Sensing area of CR signals | 100 m |
| DATA length (L_{DATA}) | 128 μ s |
| BUSY length (L_{BUSY}) | 16 μ s |
| COLL length (L_{COLL}) | 32 μ s |
| T_{rep} | SIFS (32 μ s) |
| DIFS | 64 μ s |
| $T_{collect}$ | 128 μ s |

60 seconds, and the initial transmission timing of all vehicles was set randomly based on a uniform random number during the first transmission period.

3.2 Simulation Specifications and Performance Measure

We evaluate the effectiveness of PB-TRMA using the network simulator (ns-2)¹⁶⁾. **Table 1** shows the simulation specifications.

We consider that each vehicle periodically exchanges the positional and velocity information by broadcast communications. Therefore, we set the DATA transmission period (T_p) to a constant value. According to previous studies such as Refs. 13), 14), 17) and 18), the DATA transmission period is different due to application requirements. In the present paper, we investigate the basic performance of PB-TRMA as a MAC protocol. Therefore, we set T_p to 25 ms as a constant value in order to evaluate the basic performance.

We set the communication area to 100 meters. In addition, we assume that the transmitted DATA packet from transmitters in a circular area around the receiver is correctly received, if packet collisions are not caused. We also set the sensitivity of CR signals to the same value as that of periodic broadcast packets. As a result, each vehicle senses CR signals, which were transmitted by surrounding vehicles in the communication area (i.e., 100 meters). The reason is as follows. In the case when the sensing area of CR signals is smaller than the communication area, PB-TRMA can not prevent packet collisions by hidden terminals. On the other hand, we consider the case in which the sensing area of CR signals is larger than the communication area. Vehicles cannot reserve the DATA transmission timing as the communication traffic increases such as

exposed terminal problem.

The proposed protocol requires the ability to discriminate the signal length with the resolution of a few tens of micro seconds. In Ref. 19), field operational tests were conducted in order to clarify the effectiveness of PB-TRMA. According to the report, the difference of signal length between BUSY and COLL was set to 16 micro seconds. In the experiment, the safety application in the right turn collision scene was assumed and the vehicle moved toward the intersection. Therefore, it is a practicable value to set the difference of signal length between BUSY and COLL to 16 micro seconds.

The performance of packet collision avoidance in PB-TRMA is evaluated by neglecting the capture effect in the simulation.

For quality assessment of MAC protocols, we calculate the packet success probability, which is defined as the ratio of the number of successfully received packets to that of the transmitted packets. This probability is calculated for all of the vehicles in the center square region of the road model with sides of 200 m (slashed area in Fig. 7).

4. Simulation Results

The simulation results are presented here in order to validate the effectiveness of PB-TRMA.

4.1 Basic Performance of PB-TRMA

The basic access scheme of the PB-TRMA protocol is CSMA/CA, in which packet collision avoidance is achieved using the backoff procedure⁴⁾. In the backoff procedure, the mobile terminal sets its backoff timer to a random time interval, called the backoff time ($T_{Backoff}$), based on the current contention window (CW) size:

$$T_{Backoff} = rand[0, CW] \times T_{slot}, \quad (12)$$

where T_{slot} denotes the length of a unit time slot in CSMA/CA. In addition, $rand[0, CW]$ represents the uniform random value in time period $[0, CW]$.

We first evaluate the effect of the backoff procedure on PB-TRMA. In the simulation, we set T_{slot} to 16 μ s and change CW from 0 to 15, i.e., the default minimum value of CW (CW_{min}) in IEEE 802.11a. In broadcast type communications, such as the target systems of the present study, CW_{min} is always used

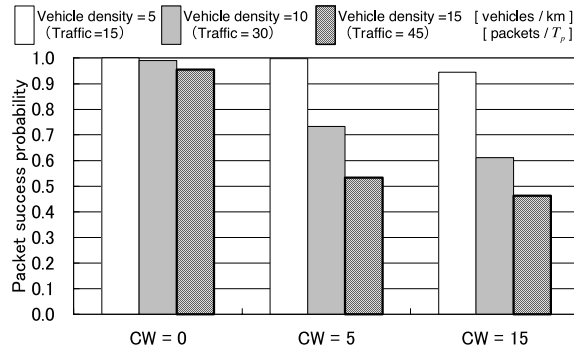

Fig. 8 Packet success probability for CW in PB-TRMA.

as CW, because an acknowledgement frame is not used.

In Fig. 8, we display the packet success probability for the contention window (CW) in PB-TRMA. The probability is calculated for 20 seconds, i.e., for 800 transmission periods, when the fluctuation of the packet success probability becomes small after the simulation is conducted for a sufficient period of time. The traffic is defined as the average number of received DATA packets per transmission period, i.e., T_p , in each vehicle. We assumed that packets from transmitters in the communication area are counted as received DATA packets even if they are lost due to packet collisions and packet errors. In the simulation, we set the vehicle density to 5, 10, and 15 vehicles per km, and then the traffic becomes 15, 30 and 45 packets per transmission period, respectively. In addition, we set the velocity of all vehicles in the simulation road model to 0 m/s and assumed that there are no packet errors in the physical layer.

Note that the packet success probability is degraded as the value of CW and the amount of traffic increases, as shown in Fig. 8. This is because, as shown in Fig. 4, even if vehicles B and C set NAV in order to avoid the packet collision with the $(n + 1)$ th DATA of vehicle A, the transmission of the $(n + 1)$ th DATA will be delayed by the backoff procedure. Therefore, the packet success probability is degraded by packet collisions.

Next, we examine the packet success probability, which is calculated every 50 ms, for the elapsed simulation time. Figures 9 and 10 illustrate the packet

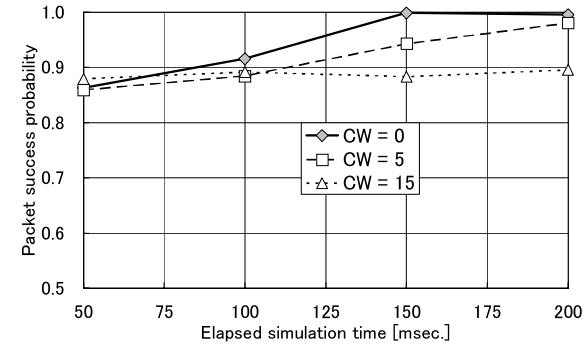

Fig. 9 Packet success probability for elapsed simulation time.

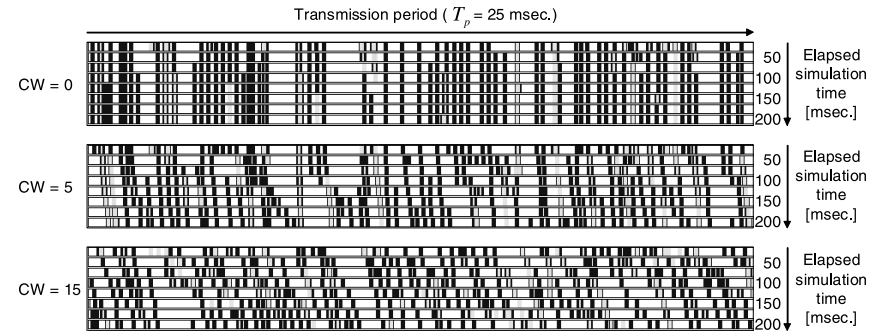

Fig. 10 Transmitted timing of DATA per transmission period ($T_p = 25$ ms).

success probability as a function of the elapsed simulation time and the transmitted timing of DATA packets of all vehicles, respectively, for the case in which we set the vehicle density to 5 vehicles per km (i.e., the traffic becomes 15 packets per transmission period).

In Fig. 10, we plot the transmitted timing of DATA packets of all vehicles in the simulation area per transmission period ($T_p = 25$ ms). In the case of $CW = 0$, the transmitted timing of DATA packets is approximately the same for every transmission period, when the elapsed simulation time exceeds 150 ms. On the other hand, for $CW = 5$ and $CW = 15$, the transmitted time of DATA packets is different for every transmission period. In addition, the difference in the trans-

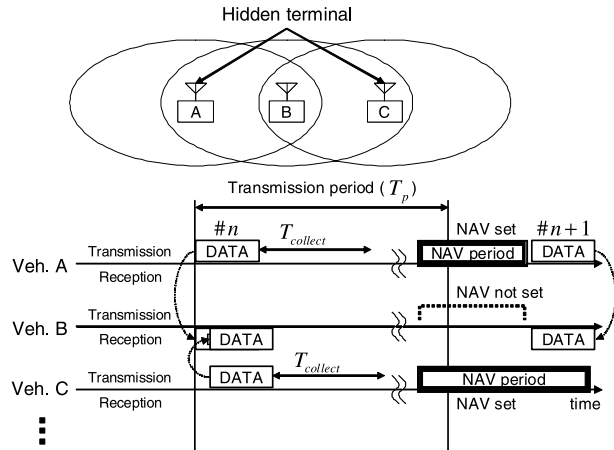

Fig. 11 Algorithm of the *PB-TRMA only BUSY* scheme for the case in which DATA packet collisions occur.

mitted timing of $CW = 15$ is larger than that of $CW = 5$. This is because the transmission of DATA packets is delayed by the backoff procedure. In addition, Fig. 9 shows that the packet success probability of $CW = 0$ is approximately 1.0 when the elapsed simulation time exceeds approximately 150 ms, i.e., packet collisions are rare.

Based on the above considerations, by neglecting the backoff procedure, i.e., using $CW = 0$, we confirm that PB-TRMA can autonomously reserve the transmitted timing to avoid packet collisions and that PB-TRMA behaves similar to TDMA.

4.2 Effect of Communication Result (CR) Signals

In order to investigate the effect of the CR signals in PB-TRMA, we compare the communication quality of the three schemes as follows.

- *PB-TRMA only BUSY*

This scheme uses only BUSY as the CR signal. Thus, when the transmitted DATA packets of vehicles A and C collide, vehicles A and C do not receive COLL in $T_{collect}$, as shown in Fig. 11. However, in this case, vehicles A and C detect packet collisions and set NAV, as shown in Fig. 3

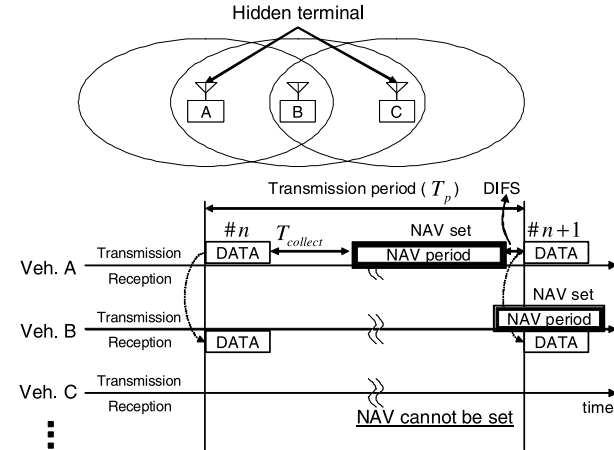

Fig. 12 Algorithm of the *PB-TRMA only COLL* scheme for the case in which the DATA packet is received correctly.

- *PB-TRMA only COLL*

This scheme uses only COLL as the CR signal. As shown in Fig. 12, vehicle A does not receive BUSY in $T_{collect}$ after transmitting DATA. However, in this case, vehicles A and B set NAV as shown in Fig. 4. On the other hand, vehicle C cannot set NAV, because vehicle C cannot detect the hidden terminal, i.e., vehicle A in Fig. 12.

- *PB-TRMA w/ BUSY and COLL* (i.e., normal PB-TRMA)

This scheme is normal PB-TRMA, as shown in Figs. 2 through 6 in the previous section.

In the simulation, we set CW of PB-TRMA and the velocity of all vehicles to 0 and 0 m/s, respectively. In addition, we assumed that there are no packet errors in the physical layer.

Figure 13 shows the packet success probability, which is calculated for 20 seconds when the fluctuation of the packet success probability becomes small after the simulation has been run for a sufficient period of time, as a function of the average traffic.

In Fig. 13 the *PB-TRMA w/ BUSY and COLL* scheme, i.e., normal PB-TRMA, achieves the best performance. In addition, the *PB-TRMA only BUSY* scheme

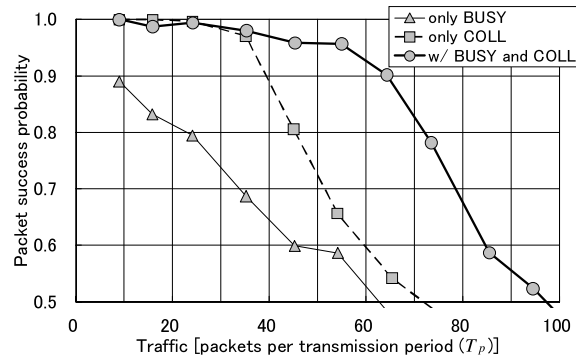

Fig. 13 Packet success probability for communication traffic in PB-TRMA.

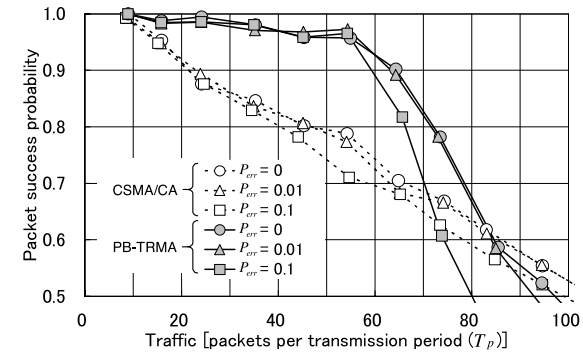

Fig. 15 Effect of packet error on PB-TRMA and CSMA/CA.

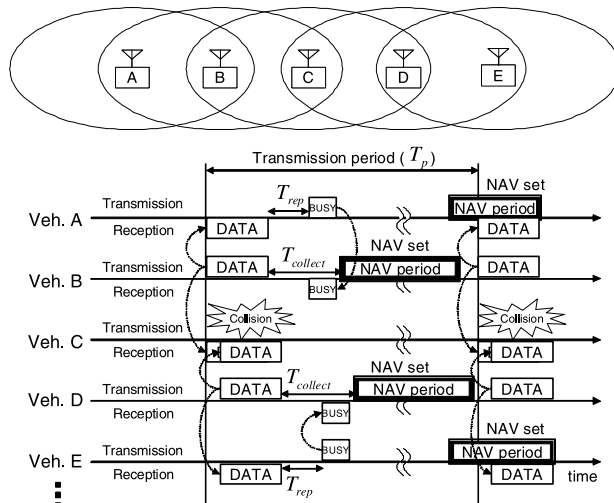

Fig. 14 Successive packet collisions in the PB-TRMA only BUSY scheme.

provides the worst performance for the entire range of traffic. The reason for this is as follows. In the case of the PB-TRMA only BUSY scheme, DATA packet collisions occur continuously for vehicle C in Fig. 14, because not all of the vehicles can detect packet collisions. On the other hand, the packet success probability of PB-TRMA only COLL is smaller than that of normal PB-TRMA.

The reason for this is that packet collisions occur because not all of the vehicles can understand the transmission timing of hidden terminals.

The above findings indicate that two procedures, namely, packet collision retrieval by COLL signal and hidden terminal detection by BUSY signal, are necessary in PB-TRMA in order to achieve high quality performance in periodic broadcast communications.

4.3 Effect of Packet Errors in Physical Layer

In order to investigate the effect of packet errors in the physical layer, we compare the communication quality of the two schemes: PB-TRMA (w/ BUSY and COLL) and CSMA/CA. We assume that a packet is randomly lost with certain probability (P_{err}) as packet errors in the physical layer. In the simulation, we changed P_{err} from 0 to 0.1 and we set the CW of PB-TRMA and that of CSMA/CA to 0 and 15, respectively. Also, we set the velocity of all vehicles to 0 m/s.

Figure 15 shows the packet success probability, which is calculated for 20 seconds when the fluctuation of the packet success probability becomes small after the simulation has been run for a sufficient period of time, as a function of the traffic.

In Fig. 15, we observe that the performance of both protocols is degraded as P_{err} increases. In particular, for $P_{err} = 0.1$, the packet success probability of PB-TRMA decreases greatly. The reason is as follows. When the vehicle can

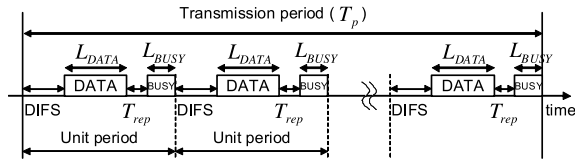

Fig. 16 Maximum number of DATA during one transmission period for PB-TRMA.

not correctly received DATA packet due to packet errors, it does not transmit a BUSY signal. Therefore, the operation of PB-TRMA (w/ BUSY and COLL) behaves similar to that of PB-TRMA only COLL.

4.4 Effect of Vehicle Mobility

Next, we compare the communication quality of three schemes: PB-TRMA (w/ BUSY and COLL), Decentralized TDMA (D-TDMA)¹²⁾ and CSMA/CA. We confirm the performance of D-TDMA as one of the TDMA protocols proposed to solve the hidden terminal problem in previous studies, because PB-TRMA behaves similar to TDMA.

D-TDMA protocol divides a frame into N time slots. Figure 16 shows the maximum number of DATA packets during one transmission period for PB-TRMA. In the present simulation, the unit period (i.e., $DIFS + L_{DATA} + T_{rep} + L_{BUSY}$) is set to $240 \mu s$, and 104 DATA packets are sent during one transmission period (25 ms). Therefore, we set the number of slots (N) to 104 for D-TDMA in our simulation. For D-TDMA communication, we herein assume that slot synchronization is established with surrounding vehicles.

In the simulation, the CW of PB-TRMA and that of CSMA/CA are set to 0 and 15, respectively. In addition, in Fig. 7, the velocity of vehicles on roads that are parallel to the y axis are varied from 0 to 20 m/s, and the velocity of other vehicles is set to 0 m/s.

Figure 17 shows the packet success probability, which is calculated for 20 seconds when the fluctuation of the packet success probability becomes small after the simulation has been run for a sufficient period of time, as a function of the average traffic. Also, we assumed that there are no packet errors in the physical layer in this simulation.

The simulation results show that D-TDMA is better than PB-TRMA for all of

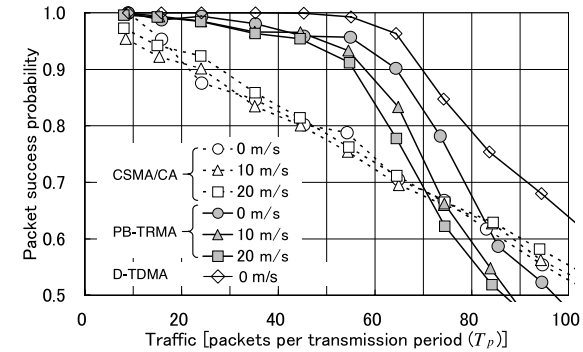

Fig. 17 Performances of PB-TRMA, D-TDMA and CSMA/CA.

the traffic situations considered herein. Therefore, we consider that the performance of TDMA protocols can give the upper-bound which can be achieved by PB-TRMA, because they divide a frame into several time slots.

Figure 17 indicates that the communication quality of PB-TRMA is better than that of CSMA/CA for all of the velocities considered herein. Packet collision due to the hidden terminal problem is the only reason for the degradation. However, the packet success probability of PB-TRMA is smaller than that of CSMA/CA when the traffic exceeds approximately 75 packets per transmission period. This is because the communication traffic increases due to the transmission of the CR signals, BUSY and COLL.

In the case of PB-TRMA, the packet success probability decreases as the velocity increases. The reason is as follows. Each vehicle changes the DATA transmission timing because packet collisions are caused by the movement of the vehicles. Therefore, the performance is degraded due to instability of the broadcast timing in T_p .

5. Conclusion

The present paper investigated MAC protocols for reliable IVC in order to support safe driving. We proposed a new MAC protocol, PB-TRMA, which can autonomously control transmission timing and avoid packet collisions by enhancing NAV to periodic broadcast communication.

The simulation results of the present study indicate that PB-TRMA can resolve the hidden terminal problem and mitigate data packet collisions. In addition, we found that two procedures, namely, packet collision retrieval by the COLL signal and hidden terminal detection by the BUSY signal, are essential to PB-TRMA in order to achieve high quality performance in periodic broadcast communications, e.g., high packet success probability. In addition, we confirmed that the proposed protocol behaves similar to TDMA and does not require autonomous slot synchronization between all of the vehicles.

In the future, we intend to investigate application-level QoS for PB-TRMA, as described in previous studies^{13),14)}. In addition, we intend to investigate traffic control schemes, such as Ref. 17) in PB-TRMA.

Acknowledgments The present study was supported by the Ministry of Internal Affairs and Communications, Japan, through the “Research and development of advanced frequency utilization technology for realization of vehicle-to-vehicle communication” project.

References

- 1) Chen, W. and Cai, S.: Ad hoc peer-to-peer network architecture for vehicle safety communications, *IEEE Commun. Mag.*, Vol.43, No.4, pp.100–107 (2005).
- 2) Misener, J., Sengupta, R. and Krishnan, H.: Cooperative collision warning: Enabling crash avoidance with wireless technology, *Proc. 12th World Congress on Intelligent Transport Systems* (2005).
- 3) ASV (online), (<http://www.mlit.go.jp/jidosha/anzen/01asv/>).
- 4) IEEE: Part 11: Wireless LAN medium access control (MAC) and physical layer (PHY) specifications, IEEE Std 802.11-2007 (2007).
- 5) Seki, K.: Data relay performance of 5.8 GHz inter-vehicle communications (The second report), *Proc. 13th World Congress on Intelligent Transport Systems* (2006).
- 6) Karn, P.: MACA – A new channel access method for packet radio, *Proc. ARRL/CRRL Amateur Radio 9th Comp. Networking Conf.*, pp.134–140 (1990).
- 7) Bharghavan, V., Demers, A., Shenker, S. and Zhang, L.: MACAW: A media access protocol for wireless LAN's, *Proc. ACM SIGCOMM'94*, pp.212–225 (1994).
- 8) Shigeyasu, T., Mtsuno, H. and Morinaga, N.: A new broadcast protocol with collision preventing schema on the basis of risk degree of hidden terminal, *IPSS Journal*, Vol.51, No.2, pp.453–465 (2010).
- 9) Tobagi, F.A. and Kleinrock, L.: Packet switching in radio channels: Part II – The hidden terminal problem in carrier sense multiple access and the busy-tone solution, *IEEE Trans. Commun.*, Vol.COM-23, pp.1417–1433 (1975).
- 10) Haas, Z.J. and Deng, J.: Dual busy tone multiple access (DBTMA) – A multiple access control scheme for adhoc networks, *IEEE Trans. Commun.*, Vol.50, No.6, pp.975–984 (2002).
- 11) Borgonovo, F., Capone, A., Cesana, M. and Fratta, L.: ADHOC MAC: New mac architecture for ad hoc networks providing efficient and reliable point-to-point and broadcast services, *Wireless Networks 10*, pp.359–366 (2004).
- 12) Makido, S., Suzuki, N., Harada, T. and Muramatsu, J.: Decentralized TDMA protocol for real-time vehicle-to-vehicle communications, *IPSS Journal*, Vol.48, No.7, pp.2257–2266 (2007).
- 13) Ito, K., Tadokoro, Y., Suzuki, N., Imai, J. and Makido, S.: An application-level QoS assessment of driving support system for safety with inter-vehicle communications, *IPSS Journal*, Vol.51, No.1, pp.83–100 (2010).
- 14) Tadokoro, Y., Ito, K., Imai, J., Suzuki, N. and Itoh, N.: A new approach for evaluation of vehicle safety communications with decentralized TDMA-based MAC protocol, *Proc. IEEE V2VCOM 2008* (2008).
- 15) Tabbane, S. and Godlewski, P.: Performance evaluation of the R-BTMA protocol in a distributed mobile radio network context, *IEEE Trans. Veh. Technol.*, Vol.41, No.1, pp.24–34 (1992).
- 16) The Network Simulator ns-2 (online), (<http://www.isi.edu/nsnam/ns/>).
- 17) Tadokoro, Y., Ito, K., Imai, J., Suzuki, N. and Itoh, N.: Advanced transmission cycle control scheme for autonomous decentralized TDMA protocol in safe driving support systems, *Proc. IEEE Intelligent Vehicles Symposium 2008*, pp.1062–1067 (2008).
- 18) Kato, S., Tsugawa, S., Tokuda, K., Matsui, T. and Fujii, H.: Vehicle control algorithms for cooperative driving with automated vehicles and intervehicle communications, *IEEE Trans. Intelligent Transportation Systems*, Vol.3, No.3, pp.155–161 (2002).
- 19) Makido, S., Hayashi, H., Imai, J., Harada, T., Ito, K., Tadokoro, Y., Tanaka, H., Suzuki, N. and Teramoto, E.: Reliable MAC protocols for next generation V2V communications -Field operation test under simulated high traffic environment, IEICE Technical Report, Vol.RCS2009-272, pp.89–94 (2010).

(Received May 14, 2010)

(Accepted December 1, 2010)

(Original version of this article can be found in the Journal of Information Processing Vol.19, pp.141–152.)



Kenji Ito received his B.S. and M.S. degrees in Electrical and Computer Engineering from Nagoya Institute of Technology, Nagoya, Japan, in 1999 and 2001, respectively. He joined Toyota Central Research and Development Laboratories, Incorporated, Aichi, Japan, in 2001. His research interests include mobile reception systems of terrestrial digital broadcasting, radio propagation modeling in inter-vehicle communications, and vehicular communication systems. Mr. Ito received the IEEE Consumer Electronics Society 2006 Chester Sall Award for the First Place Transactions Paper Award in 2008, and IPSJ Yamashita SIG Research Award in 2009. He is a member of the IEEE, IEICE and IPSJ.



Noriyoshi Suzuki received his B.E. and M.E. degrees in Electronics Engineering from Kyoto University, Kyoto, Japan, in 1990 and 1992, respectively, and received his D.E. degree from Toyohashi University of Technology, Aichi, Japan in 2003. He joined Toyota Central Research and Development Laboratories, Incorporated, Aichi, Japan, in 1992. His research interests include multi-carrier modulation techniques, digital mobile communication systems, and positioning systems. Dr. Suzuki received the Young Investigators Award from the IEICE of Japan in 1999, and the IEEE Consumer Electronics Society 2006 Chester Sall Award for the First Place Transactions Paper Award in 2008. He is a member of the IEEE, IEICE and Society of Information Theory and its Applications (SITA).



Satoshi Makido entered his Graduate School of Engineering, Nagoya University, Nagoya, Japan in 1996 and received his M.E. and Ph.D. degrees in Information Electronics in 1998 and 2003, respectively. He joined Toyota Central Research and Development Laboratories, Incorporated, Aichi, Japan in 2001. His research interests include vehicular communication systems, automotive sensor systems, and intelligent transport systems. Dr. Makido is a member of the IEICE and IPSJ.



Hiroaki Hayashi received his B.E. degree in Electrical Engineering from Nagoya Institute of Technology, Nagoya, Japan in 1989. He joined Toyota Central Research and Development Laboratories, Incorporated, Aichi, Japan in 1984. He has engaged in the research and development of analog IC, RF IC and radio system design. Mr. Hayashi is a member of the IEICE.