

Regular Paper

Two-Step Physical Register Deallocation for Data Prefetching and Address Pre-Calculation

AKIHIRO YAMAMOTO,^{†1,*1} YUSUKE TANAKA,^{†2}
HIDEKI ANDO^{†2} and TOSHIO SHIMADA^{†1}

This paper proposes an instruction pre-execution scheme for a high performance processor, that reduces latency and early scheduling of loads. Our scheme exploits the difference between the amount of instruction-level parallelism available with an unlimited number of physical registers and that available with an actual number of physical registers. We introduce the two-step physical register deallocation scheme, which deallocates physical registers at the renaming stage as a first step, and eliminates pipeline stalls caused by a shortage of physical registers. Instructions wait for the final deallocation as a second step in the instruction window. While waiting, the scheme allows pre-execution of instructions, that enables prefetching of load data and early calculation of memory effective addresses. Our evaluation results show that our scheme improves the performance significantly, and achieves a 1.26 times speedup over a processor without a prefetcher. If combined with a stride prefetcher, it achieves a 1.18 times speedup over a processor with a stride prefetcher.

1. Introduction

The load latency in cycles becomes longer as the LSI technology advances because the rate of improvement of memory access time is much slower than that of the processors clock frequency. The gap between the processor and the memory is often called a memory wall³⁰⁾. A general method to reduce the latency due to a memory wall is to fill the gap with several cache hierarchy levels, and to satisfy load requests at as a high a level as possible. However, this method is both very costly and often insufficient.

Data prefetching is an alternative or additional method of solving this problem. The method moves the necessary data, before it is actually used, from

a lower level to an upper level of the memory hierarchy in parallel with other computations, thus hiding the load latency. Many hardware schemes have been proposed for prefetching^{3),8),13),20),26)}. The schemes currently implemented in processors generally predict an access pattern, and prefetch data according to the prediction when triggered by a cache miss. Although these schemes can be implemented with a simple hardware, they are ineffective for irregular patterns that are difficult to predict. Schemes for irregular patterns have been proposed^{2),5)–7),12),15),21),23),24),35),36)}, but they have disadvantages in that they are costly to implement or require a multithreaded environment.

Even if the memory latency is perfectly hidden by prefetching, loads generally still remain on the critical paths. The schedule timing is constrained by true data dependences, that arise from program semantics and so are difficult to remove. Some predictive schemes have been proposed that remove true dependences by predicting a load address or a load value (e.g., last value predictor¹⁶⁾). A common disadvantage of these schemes is that it is difficult to achieve a sufficient improvement in performance without a complicated hardware for efficient recovery from a misprediction²²⁾.

This paper proposes a scheme that provides an instruction pre-execution within a single thread for data prefetching and load address pre-calculation^{31)–33)}. Our scheme assumes a split load/store, where the load/store operation is split into an address calculation and a memory access. Our scheme creates a pre-execution stream that precedes the main execution stream that builds the architectural state. In general, instruction execution is constrained by dependences and resource constraints. The precedence of the pre-execution stream is ensured by relaxing the imposed resource constraint. Our scheme focuses on physical registers as a resource constraint. Generally, a register file large enough to exploit fully the instruction-level parallelism (ILP) contained in a program is not implemented, because of space, time, and power constraints. This causes pipeline stalls at the register rename stage due to the shortage of physical registers. To avoid such stalls, our scheme splits the physical register deallocation into two steps at different pipeline stages. As a first step, the deallocation is carried out in the rename stage, which eliminates stalls at the rename stage and so the instructions advance and are stored in the instruction window. Our scheme allows

^{†1} Department of Electrical Engineering and Computer Science, Nagoya University

^{†2} Department of Computational Science and Engineering, Nagoya University

*1 Presently with Renesas Technology Corp.

those instructions to have a *dry run* (i.e., execution without write), forming the pre-execution stream. The final deallocation is carried out as a second step at the commit stage, as in the conventional manner. This deallocation is notified to the instructions that were allowed to use this physical register in the first step. These instructions form the main execution stream that is allowed to write results.

Our pre-execution has two advantages. First, it realizes data prefetching. Our prefetching relies on the actual execution, not on the prediction, and is thus effective for memory accesses that are difficult to predict. Second, the pre-calculation of the load address removes the true dependence of a load during the main execution. Our pre-calculation of an address writes the result to the load/store queue (LSQ). Thus, a load can immediately use the calculated address in the main execution, without having to wait for the address calculation.

The remainder of this paper is organized as follows. Section 2 illustrates the effect of our scheme. Section 3 describes related work. Our pre-execution scheme is proposed in Section 4. Section 5 presents the evaluation results and finally, our conclusions are presented in Section 6.

2. Illustration of Effects

Figure 1 illustrates the effects of our pre-execution scheme. Figure 1 (a) shows an example of the execution timing of four dependent instructions in a conventional processor, where `load` occurs a cache miss. Figure 1 (b) shows the execution timing of the same instructions with our pre-execution scheme. On the left of this figure is the pre-execution stream, while the corresponding main execution stream, not considering and considering the address pre-calculation effect, is shown on the middle and the right hand side of the figure, respectively. As shown on the left of Fig. 1 (b), pre-execution starts earlier than the conventional execution because it is not stalled by the shortage of physical registers. Thus, the cache miss of `load` occurs earlier. Handling this cache miss moves data from the lower level of the memory subsystem to the upper level. As a result, in the main execution, `load` hits the L1 data cache, resulting in a speedup. Address pre-calculation yields further speedup. The instruction `acalc` (address calculation) is pre-executed and the generated address is written into the LSQ. As a result, as shown on the right of Fig. 1 (b), in the main execution, the dependence

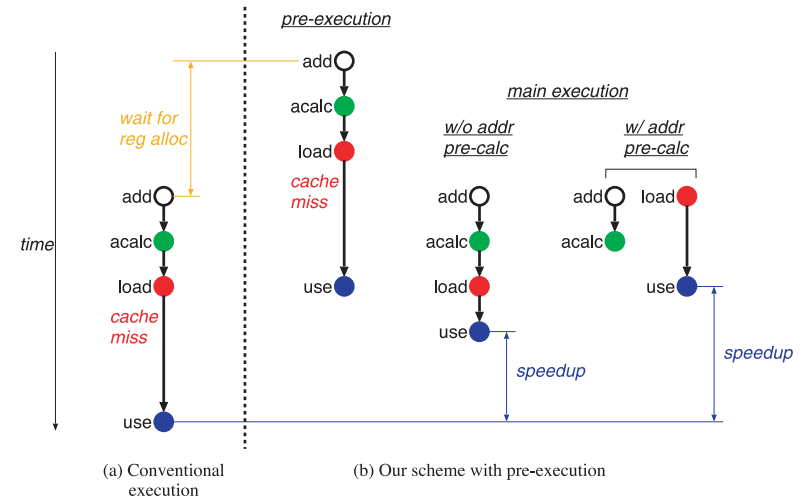

Fig. 1 Effect of our pre-execution scheme.

of load on `acalc` is resolved. Thus, `load` is executed further earlier.

3. Related Work

3.1 Data Prefetching

Jouppi proposed a *stream buffer* that automatically prefetches contiguous lines, succeeding a missed cache line, into the buffer¹³⁾. For a regular access pattern with a non-unit stride, stride prefetchers have been proposed^{3),8),20)}. Such automatic prefetchers have considerable strength in prefetch timeliness if the access pattern has a constant stride. However, they are ineffective for irregular patterns. Several prefetch schemes for irregular patterns have been proposed^{12),15),23)}. These schemes generally hold irregular pattern information for each missed address, and thus are very costly.

Our scheme is based on pre-execution. A number of studies based on pre-execution have been carried out^{2),5)-7),21),24),35),36)}. These schemes extract, either statically or dynamically, the instructions necessary for prefetching as a thread, and then spawn this thread at a certain point in the program execution to a different context of the processor. The disadvantage of these schemes is that they

require a multithreaded environment such as simultaneous multithreading²⁹⁾ or chip multiprocessors. Even in such an environment, a disadvantage arises in that the context is consumed; it may be more profitable to allocate other threads to the context for a better throughput.

The only pre-execution scheme, to our knowledge, that does not need a multithreaded environment is *runahead execution*¹⁹⁾. This scheme enters a special mode called a runahead when an L2 cache miss occurs. In this mode, the architectural state is checkpointed, and then succeeding instructions after the missed load are executed until the triggered miss is resolved. If another L2 cache miss occurs while in the runahead mode, the missed line is prefetched, overlapping memory requests. The disadvantage of this scheme is the large overhead of mode switching in both checkpointing and restarting. Therefore, its effectiveness is reduced for cache misses with relatively small, yet still important latencies like L1 cache misses. Furthermore, no computation can be overlapped with the triggered L2 miss, because the computed results during the runahead mode are discarded on returning to the normal mode.

3.2 Elimination of Address Calculation Dependence

Load address prediction is effective in eliminating the true dependence between an address calculation and a load. Value predictors^{4),16),25)} are used as an address predictor. The effectiveness of this predictive scheme depends on the prediction accuracy and the efficiency of the recovery from mispredictions. A comprehensive performance evaluation was carried out by Reinman, et al.²²⁾. They found that a simple recovery method using pipeline squashing significantly reduces the effectiveness, and a more elaborate method where only dependent instructions are re-executed is necessary for the performance improvement to be sufficient. However, this complicates the issue logic, thus adversely affecting the clock cycle time.

3.3 Effectively Enlarging Register File

Several studies, aimed at effectively enlarging register files, have been done in an attempt to reduce the occupation time of physical registers by a late allocation^{9),17)} or an early deallocation^{1),18),28)} of these registers.

Early deallocation schemes deallocate registers speculatively by predicting a last consumer, and allocate them at the rename stage. The shortcomings of such

schemes include the large penalty imposed by a mis-speculation recovery, and the requirement of a large checkpointing register file that includes a shadow storage.

Late allocation schemes do not allocate registers at the rename stage; instead, they are allocated later in the pipeline. The *virtual-physical register scheme*^{9),17)} allocates registers at the write-back stage. This scheme is similar to our scheme in that instructions are executed even if physical registers have failed to be allocated, thus realizing pre-execution. Unfortunately, this scheme has a complication in avoiding a deadlock due to an out-of-order physical register allocation. A feasible, yet still complicated implementation imposes a considerable cycle count penalty, and causes a significant increase in the dynamic instruction counts by an ad hoc register reallocation and the resulting instruction's re-execution. We compare our scheme with the virtual-physical register scheme in Section 5.6.

4. Pre-Execution Microarchitecture

Our scheme assumes a register renaming scheme, where the register file contains committed values and temporary values for instructions that have been completed but not yet committed, and a map table translates a logical register number into a physical one. This type of register renaming is, for example, implemented in the MIPS R10000³⁴⁾ and in the Digital Equipment Alpha 21264¹⁴⁾. In this section, we first propose a two-step physical register deallocation scheme as the basic scheme, and then extend this scheme to enable pre-execution.

4.1 Basic Scheme

We first describe the first-step deallocation, and then describe the second-step deallocation.

4.1.1 First-Step Deallocation

The first-step deallocation is performed in the rename stage. Besides the map table and the free list, we prepare a table called the *deallocation table* (DAT). Each entry in the DAT is associated with a physical register, and holds a valid bit and the number of the reorder buffer (ROB) entry, where the instruction that finally deallocates the corresponding physical register is placed.

The operations are as follows. First, when an instruction reaches the rename stage, the physical register that is currently allocated to the same logical destination register of the instruction is *temporarily* deallocated, and is appended

to the free list. At the same time, the number of the ROB entry, to which the instruction has been allocated, is written into the DAT entry associated with the deallocated physical register, and the entry is validated. In addition, an available physical register is obtained from the free list, and is newly allocated to the logical destination register as in the conventional method. At this time, by looking up the DAT, we obtain the number of the ROB entry (ROBP), where an instruction that will *finally* deallocate the physical register has been placed, if such an instruction is still in the ROB (in this case, the DAT entry found is valid; otherwise, the entry is invalid, meaning that the instruction has already been committed and the final deallocation has been performed). The ROBP (if obtained) is attached to the renaming instruction as a tag to find the timing of the second-step deallocation later in the instruction window (as described in Section 4.1.2).

Figure 2 illustrates an example of the operation described above. The table presents an allocated physical register, a deallocating physical register, and an allocated ROB entry number, for each instruction in the first column. Figure 2 (a) illustrates the operations when instructions *i0* and *i1* have already been renamed, and *i2* is being renamed. First, the physical register 36, currently allocated to a logical destination register *r2*, is deallocated, and appended to the free list (mark (1) in Fig. 2 (a)). At the same time, the allocated ROB entry number 13 is written into the 36th entry of the DAT (mark (2)).

Next, Fig. 2 (b) illustrates the operations when instruction *i3* is being renamed. The physical register 36 that was deallocated by the instruction *i2* has been allocated to this instruction. After the deallocation and the allocation of the physical registers as described, we obtain, by referring to the DAT (mark (3) in Fig. 2 (b)), the ROB entry number 13, containing the instruction *i2* that will finally deallocate the allocated physical register 36 (in the second-step deallocation).

This number is attached to the renaming instruction *i3* as an ROBP tag, and will be written into the instruction window along with the destination register tag (dtag) and two source register tags (stag_l and stag_r) (mark (4)). Note that physical register numbers are not used as operand tags. Instead arbitrary unique numbers are used to identify the dependences of the instructions in flight, because physical register numbers cannot differentiate between dependences due to the

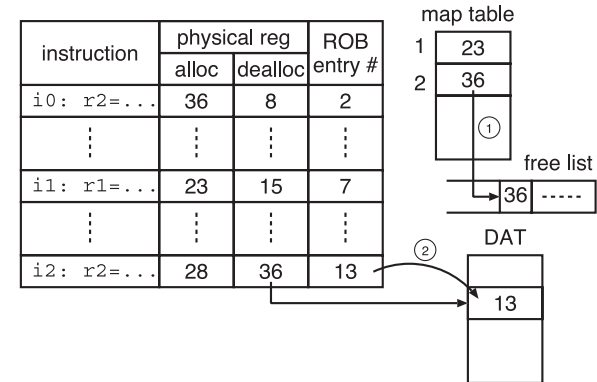

(a) At renaming of instruction *i2*

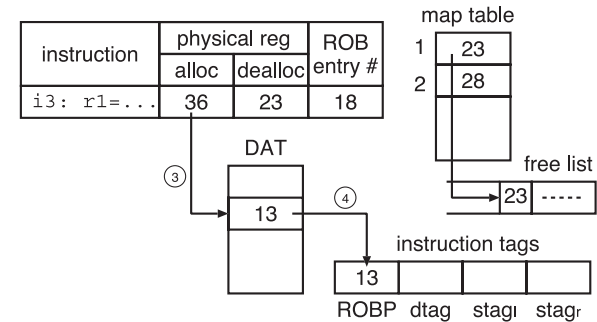

(b) At renaming of instruction *i3*

Fig. 2 First-step deallocation.

temporary deallocation at the rename stage.

4.1.2 Second-Step Deallocation

The renamed instruction is stored in the instruction window, and waits for the second-step deallocation of its destination physical register, that is performed at the commit stage. The deallocated physical register at this time is one that was previously allocated to the logical register as is the case in the conventional scheme. The scheme differs, however, in that it broadcasts the number of the committed ROB entry, ROBP, to the instruction window. If the broadcasted ROBP matches the ROBP tag of an instruction waiting in the instruction win-

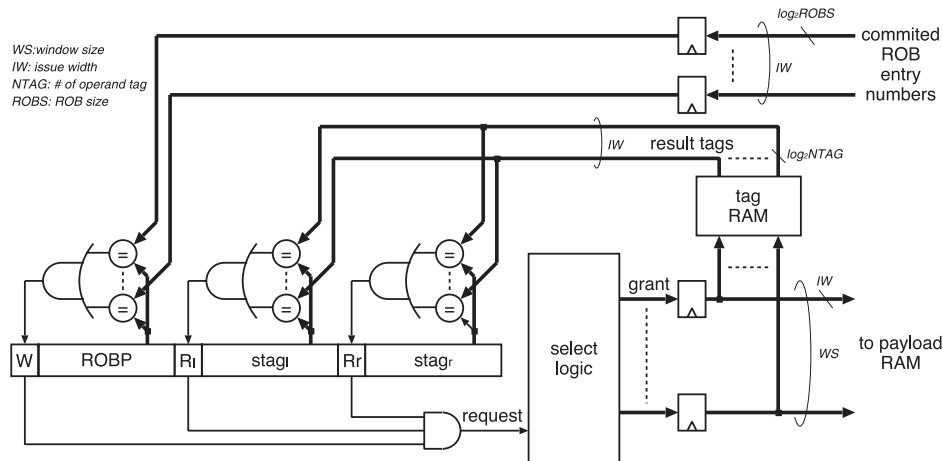

Fig. 3 Instruction scheduler in our basic scheme.

down, the write of the result is granted. Also, the DAT entry associated with the deallocated physical register is invalidated.

In the example shown in Fig. 2, the second-step deallocation of the physical register 36 is performed when the instruction *i2* is committed. The ROB entry number 13 is then broadcast to the instruction window. It is matched with the ROBP tag of the instruction *i3*, and the result write of this instruction is granted.

The logic circuit of the instruction scheduler in our basic scheme is shown in Fig. 3. The three tags, ROBP, $stag_l$, and $stag_r$, are held in the wakeup logic for each instruction. The three flags, W, R_l , and R_r , associated with each tag are also held. Flags R_l and R_r are the conventional ready flags indicating that the corresponding source operands are available. Flag W indicates that the result write of the corresponding instruction has been granted. When an instruction is issued, its destination tag, also called a result tag, is read from the tag RAM, and is broadcast to the wakeup logic. The tag match is checked with the comparator, and the ready flag is set if a match occurred as in the conventional scheme. On the other hand, the ROB entry number sent from the ROB is compared with each ROBP tag, and the flag W is set if a match occurs. If flags W, R_l , and R_r are all set, an issue request is sent to the select logic. If selected, the instruction

is executed and the result is written as in the normal method.

Note that, for instructions that do not obtain a valid ROBP in the rename stage, flag W is initially set when they are written into the instruction window. Since their destination physical register has already been finally deallocated, an issue control by the flag W is not necessary. Also, instructions that do not have destination registers, such as the address calculation instructions of memory instructions, are controlled in the same manner, because these instructions do not require register writes.

4.2 Extension to Instruction Pre-Execution

In the previous section, we mentioned that instructions waiting in the instruction window are not allowed to be issued until their writes have been granted. However, it is possible for such instructions to be executed; although the execution result is not written, it can be passed to dependent instructions via the bypass logic if the instructions are issued continuously. These instructions form a pre-execution stream, which proceeds faster than the main execution stream because it exploits ILP, where no resource constraint concerning physical registers exists.

Figure 4 shows the logic circuit diagram of the instruction scheduler that implements our pre-execution scheme. The main differences between this extended scheduler logic and the logic of the basic scheme shown in Fig. 3 are the following: 1) A T-FF is placed in the issue request logic to allow the pre-execution only once before a write is granted. 2) A flag we call *pexec* is attached to the result tag of each pre-executed instruction. This flag is used to reset the ready flag that was set in the previous cycle.

When an instruction is written into the instruction window, the T-FF in the corresponding entry is set. When the execution of an instruction finishes, its result tag is broadcast. The ready flag in the entry matching the tag is set. When both ready flags, R_l and R_r , are set, the issue request is sent to the select logic through the issue request logic, even if flag W is 0, because the T-FF is 1. If the request is granted, the selected instruction is issued and pre-executed. The grant signal toggles the T-FF to 0, and thus an issue request will not be produced until flag W has been set. Also, *pexec* flags are generated, and will reset the ready flags in the next cycle

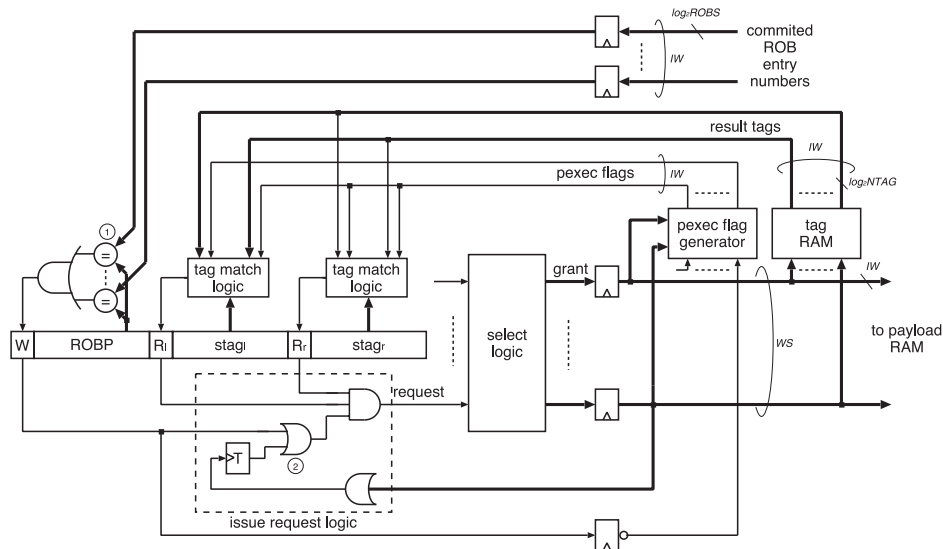

Fig. 4 Instruction scheduler for pre-execution.

Note that pre-executed instructions are not removed from the instruction window. Later, when the flag W is set by an ROBP tag match, and both ready flags are set again, the instruction is re-executed and writes the result into the destination physical register, as described in Section 4.1.2.

4.3 Delay Problems

Since the instruction scheduler is one of the critical circuits that determine the clock cycle time of a processor, we need to check whether or not the circuits added to the instruction scheduler affect the delay. The critical path of the original scheduler consists of the grant drive, the tag RAM access, the tag drive, the tag match, ORing the match results, setting the ready flag, ANDing the ready flags, and the select. The potential problematic path that is most concerning in our scheduler is the one related to flag W . This path consists of the drive of ROB entry numbers, the matching the ROBP (mark (1) in Fig. 4), ORing the match results, setting flag W , ORing the flag W with the T-FF (mark (2)), ANDing the ready flags, and the select. Compared with the original critical path, this delay is shorter with respect to the tag RAM access time, but is longer with respect

to the time for ORing with the T-FF. Apparently, the time for ORing with the T-FF is much shorter than the tag RAM access time. Therefore, the delay for the path related to flag W is shorter than that for the original critical path.

4.4 Combining with Automatic Prefetcher

Automatic prefetchers, like stride prefetchers, have a big advantage in that they can automatically and promptly prefetch enough data in a long stream with a regular pattern. On the other hand, although our pre-execution scheme can prefetch data with both regular and irregular patterns, the prefetching rate is bounded by the fetch rate of load instructions. This restriction is particularly disadvantageous in a long stream with a regular pattern.

Considering both the strengths and the weaknesses, combining the two prefetching schemes compensates for the weaknesses in each scheme; the automatic prefetcher covers the miss stream with a regular pattern, and our pre-execution prefetching covers the miss stream with an irregular pattern. This combination also provides additional benefits. First, the automatic prefetcher helps advance the pre-execution faster, because part of the cache misses during the pre-execution can be avoided with the automatic prefetcher. This improves the timeliness of prefetching with an irregular pattern. Second, our pre-execution triggers the automatic prefetcher earlier, improving the timeliness of prefetching with a regular pattern.

5. Evaluation

To evaluate our scheme, we built a simulator based on the SimpleScalar Tool Set version 3.0a²⁷⁾. The instruction set is SimpleScalar/PISA, which is an extension of the MIPS R10000 ISA. We use nine memory intensive programs from SPECfp95 and SPECfp2000. We have chosen the nine programs with the highest L1 data cache miss rate from the programs in the two suites that we could compile for SimpleScalar. **Table 1** lists the benchmark programs and their L1 data and L2 unified cache miss rates. The programs are compiled using gcc ver.2.7.2.3 with options `-O6 -funroll-loops`.

The configuration of the baseline processor for our evaluation is summarised in **Table 2**. As expected, our scheme achieves a higher performance improvement over the base with a larger ROB and a smaller register file, because, with such a

Table 1 Cache miss rate.

suite	program	miss rate	
		L1 data	L2
SPECfp95	hyrdro2d	8%	31%
	su2cor	7%	0%
	wave5	4%	7%
SPECfp2000	ammp	9%	32%
	applu	5%	49%
	art	48%	44%
	equake	5%	41%
	mgrid	3%	30%
	swim	13%	36%

Table 2 Baseline processor configuration.

Pipeline width	8-instruction wide for each of fetch, decode, issue, and commit
ROB	128 entries
Instruction window	64 entries
LSQ	64 entries
Function unit	8 iALU, 4 iMULT/DIV, 4 Ld/St, 6 fpALU, 4 fpMULT/DIV/SQRT
L1 I-cache	64 KB, 2-way, 32 B line
L1 D-cache	64 KB, 2-way, 32 B line, 4 ports, 2-cycle hit latency, non-blocking
L2 cache	2 MB, 4-way, 64 B line, 12-cycle hit latency
Main memory	300-cycle minimum latency, 8 B/cycle bandwidth
Branch prediction	6-bit history gshare, 8 K-entry PHT, 10-cycle misprediction penalty
Physical register	total 192 (96 for each of integer and floating-point)
Mem. disambiguation	perfect

configuration, many instructions stalls due to the shortage of physical registers in the conventional processor, while such instructions can be pre-executed with the support of the large ROB in our scheme. For fair evaluation, we conservatively determined the relationship between the ROB and register file sizes, to be *balanced* in the conventional microarchitecture. We used the following equation:

$$N_{pregs} = ROB\ size + N_{lregs} \quad (1)$$

where N_{pregs} and N_{lregs} are the total number of physical and logical registers, respectively. The ROB size and the number of physical registers determined by equation (1) are balanced in that 1) the ROB size gives the number of supported in-flight instructions, and most in-flight instructions require a physical register, and 2) each committed logical destination register requires a physical register.

Table 3 Percentage of dynamic instructions categorized by type of destination register.

program	type of destination register			
	int	fp	other	none
hydro2d	46%	28%	4%	21%
su2cor	51%	32%	0%	16%
wave5	41%	41%	2%	16%
ammp	24%	55%	1%	20%
applu	60%	31%	1%	8%
art	37%	39%	2%	22%
equake	58%	16%	0%	26%
mgrid	43%	55%	1%	2%
swim	48%	48%	0%	4%
AVG	45%	38%	1%	15%

Next, we divided the total number of physical registers equally between integer and floating-point registers. This is reasonable as the number of dynamic instructions with destination registers being either integer or floating point is roughly equal in the benchmark programs we used. **Table 3** lists the percentage of dynamic instructions categorized by the type of the destination register in the baseline processor. Finally, we determined the instruction window size and the LSQ size to be half the ROB size. In Sections 5.4 and 5.5, we present the evaluation results showing the sensitivity of the ROB and the register file sizes to performance.

Finally, we also assume a perfect memory disambiguation for fair evaluation. Our pre-calculation of the load address has a positive effect on the memory disambiguation. For fair evaluation, instead of implementing memory dependence predictors in our base simulator, we assume a perfect memory disambiguation to exclude the effects on memory disambiguation.

5.1 Effect of Data Prefetching

We evaluate the average load latency of the following three models. The first is the *stride prefetcher model*, which is the baseline processor with a stride prefetcher using a per-load stride predictor⁸⁾. It has a stream buffer¹³⁾ between the L1 data cache and the L2 unified cache to avoid the pollution of the L1 data cache. The stream buffer is accessed in parallel with the L1 data cache, and the requested data is assumed to be obtained with a single cycle latency, if it is found. The configuration of the stream buffer is determined based on the hardware prefetching

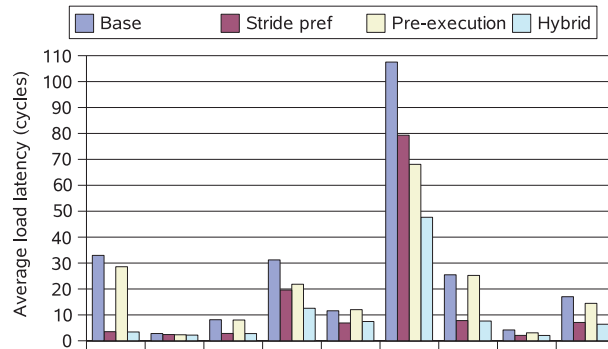

Fig. 5 Average load latency.

scheme of an Intel Pentium 4¹¹⁾. The buffer has eight ways, the capacity of each being 4KB each, and the line size 32B. The buffer is allocated on an L1 data cache miss. To suppress prefetching of useless data, the incremental prefetching scheme⁸⁾ proposed by Farkas et al. is introduced.

The second model is the *pre-execution model*, which incorporates our pre-execution scheme into the baseline processor. A stream buffer is not placed.

The third model is a *hybrid model* that combines the pre-execution and the stride prefetcher models.

Figure 5 shows the average load latency for each model. As shown in the figure, the pre-execution model reduces the load latency significantly compared to the base model for many programs.

Intuitively, the effectiveness of the pre-execution model depends on how well pre-execution is performed. In other words, the effectiveness correlates to how well pre-execution is performed. To confirm this, we introduce the following metric, which we call *precedence cycles per load* (PCPL):

$$PCPL = \frac{\sum_{pre-executed\ load} precedence\ cycles}{total\ number\ of\ loads}$$

where *precedence cycles* is defined as how many cycles the pre-execution of a

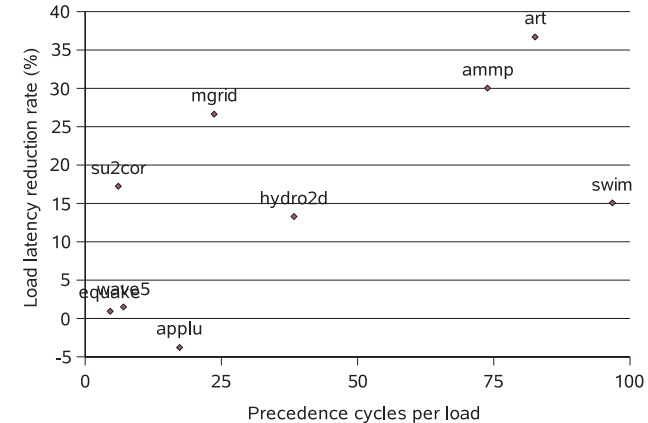

Fig. 6 Correlation between load latency reduction rate and precedence cycles per load.

load is earlier than the main execution of the load. Note that we focus only on committed loads in this definition. PCPL becomes larger as more loads are pre-executed and/or the number of precedence cycles in a pre-executed load grows.

Figure 6 shows the correlation between the load latency reduction rate from the base and PCPL. As expected, a correlation can be confirmed, although it is weak. The reason that the correlation is weak is that the contribution to the load latency reduction depends on whether or not pre-executed loads incur a cache miss and at which level the miss occurs. This weak correlation indicates the inefficiency of our data prefetching in terms of power consumption, because useless pre-execution may be performed. If we can focus on loads that incur a cache miss and pre-execute only the instructions related to such loads, a more efficient pre-execution will be achieved. This is our work in progress¹⁰⁾.

Let us return to Fig. 5. Compared with the stride prefetcher model, the pre-execution model is better in *art*, and comparable in *su2cor* and *ammp*. However, in other programs, the stride prefetcher model performs better than the pre-execution model. Figure 7 shows the hit rate of the stream buffer for missed accesses to the L1 data cache in the stride prefetcher model. The lower and upper portions of each bar represent full and partial hits, respectively. In many programs, the stride prefetcher performs well, and thus it is difficult for the pre-

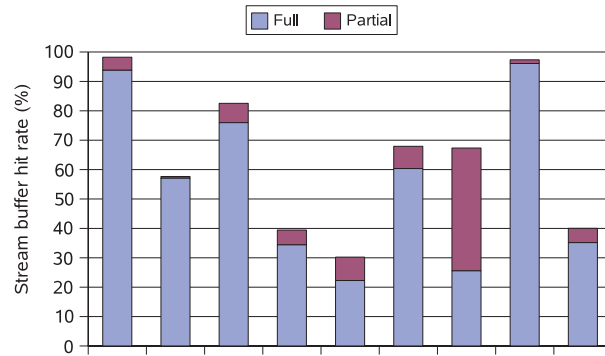

Fig. 7 Stream buffer hit rate.

execution model to outperform the stride prefetcher model on average. However, it is also a fact that misses it cannot cover remain in many programs.

The hybrid model covers those remaining misses with our pre-execution, and thus exhibits the lowest load latency of the four evaluated models for most programs. In particular, in *ammp* and *art*, the hybrid model significantly reduces the load latency when compared to both the stride prefetcher model and the pre-execution model.

5.2 Effect of Address Pre-Calculation

Here, we evaluate the effect of address pre-calculation. To exclude the prefetch effect, we assume that the L1 data cache is perfect in the evaluation in this section.

Figure 8 shows the speedup of the pre-execution model over the baseline model, with a perfect L1 data cache for both models. As shown in Fig. 8, the speedup is less than 10% in most programs, but a significant speedup is attained in *mgrid* and *swim*.

5.3 Overall Performance

We now evaluate the overall performance of our scheme. Figure 9 compares the IPC of the four models. As shown in this figure, our pre-execution model achieves a speedup of 26% on average over the base model. Note that our scheme achieves this significant speedup with a modest hardware cost and with little

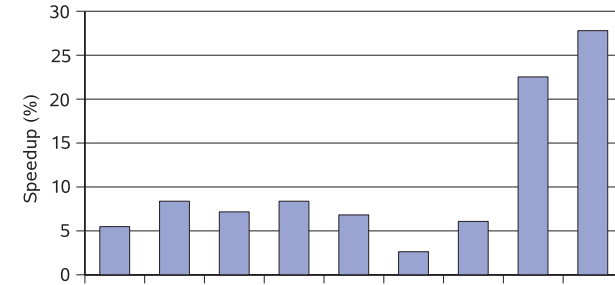

Fig. 8 Effect of address pre-calculations.

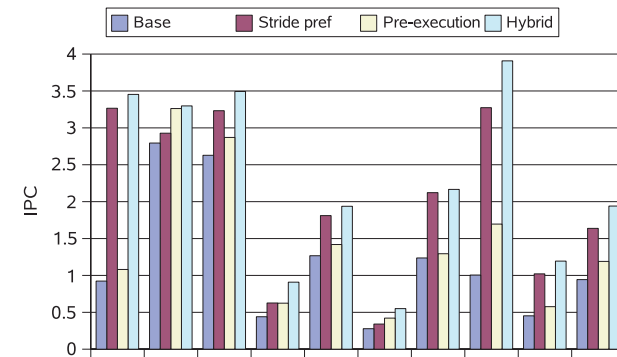

Fig. 9 Overall performance.

adverse impact on the clock cycle time. Although the performance of the pre-execution alone is 27% worse than that of the stride prefetcher model on average, the hybrid model exhibits a considerably better performance. The speedup over the stride prefetcher model is 18%.

5.4 Performance Sensitivity to the Balance between Register File Size and ROB Size

As stated before, the effectiveness of our scheme is sensitive to the balance

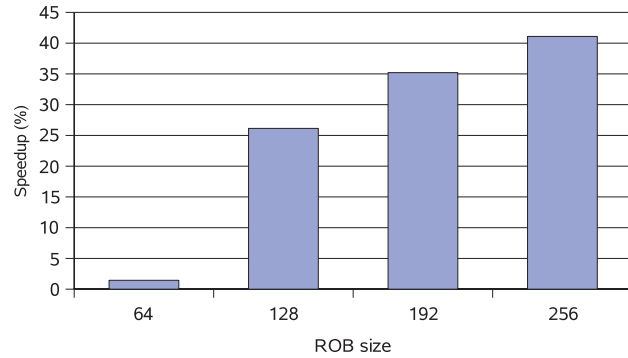

Fig. 10 Impact of balance between register file size and reorder buffer (total of register file size is fixed to 192).

between the register file size and the ROB size. This section evaluates the performance sensitivity with respect to this balance by varying the ROB size, while keeping the register file size constant (our default: a total of 192). The size of the instruction window and the LSQ is half the ROB size, and the other configuration parameters are left unchanged.

Figure 10 shows the evaluation results. The horizontal axis represents the ROB size, while the vertical axis represents the speedup (geometric mean) of the pre-execution model over the base model. Note that each speedup is calculated independently for each different size.

As shown in the figure, a small ROB causes the effectiveness of our scheme to deteriorate significantly (see the case of a 64-entry ROB). Instructions are stalled by the shortage of the ROB entries before being stalled by the shortage of physical registers. On the other hand, a large ROB is significantly beneficial to our scheme by supporting more pre-execution instructions.

5.5 Performance Sensitivity to Size of Critical Resources

This section evaluates how the effectiveness of our scheme varies by enlarging the critical resources (the register file, the ROB, the instruction window, and the LSQ) simultaneously while maintaining their balance (refer to the beginning of Section 5). Other configuration parameters are left unchanged.

We can anticipate that the effectiveness of our scheme diminishes, as the re-

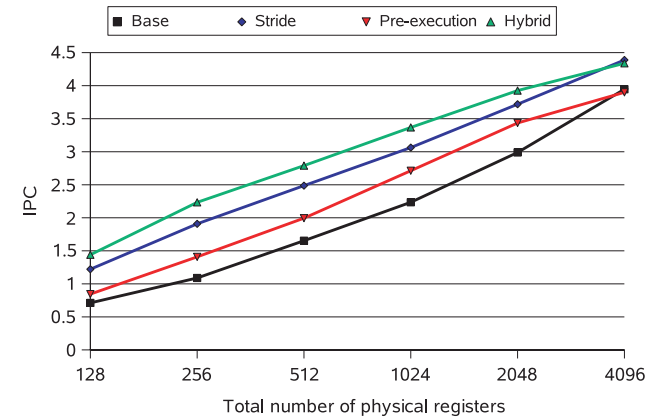

Fig. 11 IPC vs. size of critical resources.

sources is enlarged, for the following two reasons. 1) As described previously, our scheme exploits the difference between the available amount of ILP with an unlimited number of physical registers and that with an actual number of physical registers. Therefore, as the number of physical registers increases, the effectiveness will decrease. 2) As the size of the critical resources increases, cache miss latency will be hidden more by the execution of instructions independent of the miss. This diminishes the impact of prefetching in our scheme on the performance.

Figure 11 shows the evaluated IPC (geometric mean) of the four models for the different sizes of the four critical resources. The horizontal axis represents the total number of physical registers, as a representative of the four resources. Unexpectedly, the speedup of the pre-execution model over the base increases with the small size of resources; the speedup increases from 19% to 29% when the number of physical registers increases from 128 to 256. We believe that this is because the positive impact caused by more resources available for pre-execution exceeds the negative impact described previously. As anticipated, however, the speedup gradually decreases as the size of the resources increases above 256 physical registers (29% at 256 physical registers to -0.1% at 4,096 physical registers). A similar observation is found in the speedup of the hybrid model over the stride

model. Although our scheme becomes ineffective with an impractically large size of the critical resources, it is sufficiently effective over a wide range of the sizes of the critical resources.

5.6 Comparison with Virtual-Physical Register Scheme

As described in Section 3.3, the virtual-physical (VP) scheme has the ability to prefetch data as in our scheme. Here, we compare our scheme with the VP scheme, which employs DSY (on-demand with steeling from younger)¹⁷⁾ to avoid any deadlock. We introduce two models for the VP scheme with different cycles consumed for register reallocation in the DSY. One is an *ideal DSY model*, which is ideal in that no cycle is consumed for register reallocation. The other is a *real DSY model*, which limits the ROB read bandwidth to the commit width (eight in our assumption) when searching for a victim to reallocate a register and stalls the execution and commit stages of the pipeline while searching (the memory subsystem is not stalled).

Figure 12 (a) shows the IPCs. As shown in this figure, the IPC of our scheme is comparable with the ideal DSY. However, taking into account the register reallocation cost, the real DSY model significantly degrades the performance. In addition, the VP scheme considerably increases the dynamic instruction count, as shown in Fig.12 (b) (the vertical axis indicates the percent increase of the dynamic instruction count over the committed instruction count). This increases power consumption.

6. Conclusions

In this paper, we have proposed a scheme that prefetches data and pre-calculates the address of loads. Our scheme allows instructions to be pre-executed in a single context by exploiting the difference between the available amount of ILP without resource constraints of the physical registers and that of ILP with these constraints. Execution-based data prefetching enables prefetching of data with an irregular access pattern. Our scheme is implemented by a simple table that maintains early register deallocation and a modestly modified instruction scheduler. Our evaluation results show that our scheme significantly improves the performance by 26% over a processor without a prefetcher. Considering the strength of an automatic prefetcher for a regular access pattern, we believe that

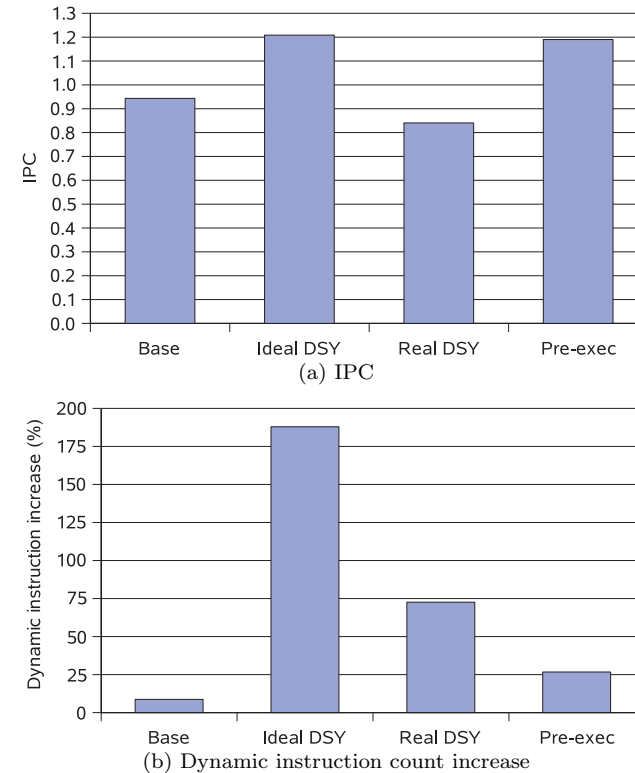

Fig. 12 Comparison with virtual-physical register scheme.

combining it with our scheme offers its best use. The combined scheme improves the performance by 18% over a processor incorporating only a stride prefetcher.

Acknowledgments This work was partially supported by The Ministry of Education, Culture, Sports, Science and Technology Grant-in-Aid for Scientific Research (C)(No.19500041).

References

- 1) Balkan, D., Sharkey, J., Ponomarev, F. and Aggarwal, A.: Address-Value Decoupling for Early Register Deallocation, *Proc. 2006 International Conference on*

- Parallel Processing*, pp.337–346 (2006).
- 2) Chappell, R., Stark, J., Kim, S., Reinhardt, S. and Patt, Y.: Simultaneous Subordinate Microthreading (SSMT), *Proc. 26th Annual International Symposium on Computer Architecture*, pp.186–195 (1999).
 - 3) Chen, T.F. and Baer, J.L.: Reducing Memory Latency via Non-Blocking and Prefetching Caches, *Proc. Fifth Annual International Conference on Architectural Support for Programming Languages and Operating Systems*, pp.51–61 (1992).
 - 4) Chen, T.F. and Baer, J.L.: Effective Hardware-based Data Prefetching for High Performance Processors, *IEEE Transactions on Computers*, Vol.44, No.5, pp.609–623 (1995).
 - 5) Collins, J.D., Sair, S., Calder, B. and Tullsen, D.M.: Pointer Cache Assisted Prefetching, *Proc. 35th Annual International Symposium on Microarchitecture*, pp.62–73 (2002).
 - 6) Collins, J.D., Tullsen, D.M., Wang, H., Lee, Y., Lavery, D., Shen, J.P. and Hughes, C.: Speculative Precomputation: Long-Range Prefetching of Delinquent Loads, *Proc. 28th Annual International Symposium on Computer Architecture*, pp.14–25 (2001).
 - 7) Collins, J.D., Tullsen, D.M., Wang, H. and Shen, J.P.: Dynamic Speculative Precomputation, *Proc. 34th Annual International Symposium on Microarchitecture*, pp.306–317 (2001).
 - 8) Farkas, I., Chow, P., Jouppi, N.P. and Vranesic, Z.: Memory-System Design Considerations for Dynamically-scheduled Processors, *Proc. 24th Annual International Symposium on Computer Architecture*, pp.133–143 (1997).
 - 9) González, A., González, J. and Valero, M.: Virtual-Physical Registers, *Proc. fourth Annual International Symposium on High Performance Computing*, pp.175–184 (1998).
 - 10) Hyodo, K. and Ando, H.: A Low-Power Design of Instruction Pre-Execution Mechanism with Two-Step Physical Register Deallocation, *IPJS SIG Technical Reports*, Vol.2007-ARC-174, pp.169–174 (2007).
 - 11) Intel Corporation: *Intel Pentium 4 Processor Optimization Reference Manual* (1999).
 - 12) Joseph, D. and Grunwald, D.: Prefetching using Markov Predictors, *Proc. 24th Annual International Symposium on Computer Architecture*, pp.252–263 (1997).
 - 13) Jouppi, N.P.: Improving Direct-Mapped Cache Performance by the Addition of a Small Fully Associative Cache and Prefetch Buffers, *Proc. 17th Annual International Symposium on Computer Architecture*, pp.364–373 (1990).
 - 14) Kessler, R.E.: The Alpha 21264 Microprocessor, *IEEE Micro*, Vol.19, No.2, pp.24–36 (1999).
 - 15) Lai, A., Fide, C. and Falsafi, B.: Dead-Block Prediction and Dead-Block Correlating Prefetchers, *Proc. 28th Annual International Symposium on Computer Architecture*, pp.144–154 (2001).
 - 16) Lipasti, M.H., Wilkerson, C.B. and Shen, J.P.: Value Locality and Load Value Prediction, *Proc. Seventh International Conference on Architecture Support for Programming Languages and Operating Systems*, pp.138–147 (1996).
 - 17) Monreal, T., González, A., Valero, M., González, J. and Viñals, V.: Delaying Physical Register Allocation through Virtual-Physical Registers, *Proc. 32nd Annual International Symposium on Microarchitecture*, pp.186–192 (1999).
 - 18) Moudgill, M., Pinagli, K. and Vassiliadis, S.: Register Renaming and Dynamic Speculation: An Alternative Approach, *Proc. 26th Annual International Symposium on Microarchitecture*, pp.202–213 (1993).
 - 19) Mutlu, O., Stark, J., Wilkerson, C. and Patt, Y.N.: Runahead Execution: An Effective Alternative to Large Instruction Windows, *Proc. Ninth Annual International Symposium on High-Performance Computer Architecture*, pp.129–140 (2003).
 - 20) Palacharla, S. and Kessler, R.E.: Evaluating Stream Buffers as a Secondary Cache Replacement, *Proc. 21st Annual International Symposium on Computer Architecture*, pp.24–33 (1994).
 - 21) Purser, Z., Sundaramoorthy, K. and Rotenberg, E.: A Study of Slipstream Processors, *Proc. 33rd Annual International Symposium on Microarchitecture*, pp.269–280 (2000).
 - 22) Reinman, G. and Calder, B.: Predictive Techniques for Aggressive Load Speculation, *Proc. 31st International Symposium on Microarchitecture*, pp.127–137 (1998).
 - 23) Roth, A. and Sohi, G.S.: Effective Jump-Pointer Prefetching for Linked Data Structures, *Proc. 26th Annual International Symposium on Computer Architecture*, pp.111–121 (1999).
 - 24) Roth, A. and Sohi, G.S.: Speculative Data-driven Multithreading, *Proc. 7th Annual International Symposium on High Performance Computer Architecture*, pp.37–48 (2001).
 - 25) Sazeides, Y. and Smith, J.E.: The Predictability of Data Values, *Proc. 30th International Symposium on Microarchitecture*, pp.248–258 (1997).
 - 26) Sherwood, T., Sair, S. and Calder, B.: Predictor-Directed Stream Buffers, *Proc. 33rd Annual International Symposium on Microarchitecture*, pp.42–53 (2000).
 - 27) <http://www.simplescalar.com/>.
 - 28) Srinivasan, S.T., Rajwar, R., Akkary, H., Gandhi, A. and Upton, M.: Continual Flow Pipelines, *Proc. 11th International Conference on Architectural Support for Programming Languages and Operating Systems*, pp.107–119 (2004).
 - 29) Tullsen, D.M., Eggers, S. and Levy, H.M.: Simultaneous Multithreading: Maximizing On-Chip Parallelism, *Proc. 22nd Annual International Symposium on Computer Architecture*, pp.392–403 (1995).
 - 30) Wulf, W.A. and McKee, S.A.: Hitting the Memory Wall: Implications of the Obvious, *ACM SIGARCH Computer Architecture News*, Vol.23, No.1, pp.20–24 (1995).
 - 31) Yamamoto, A., Ando, H. and Shimada, T.: Two-Step Physical Register Deallocation for Superscalar Processors, *IPJS SIG Technical Reports*, Vol.2005-ARC-164,

pp.7–12 (2005).

- 32) Yamamoto, A., Ando, H. and Shimada, T.: Latency Reduction and Precise Scheduling of Loads through Pre-Execution, *Symposium on Advanced Computing Systems and Infrastructures*, pp.403–410 (2006).
- 33) Yamamoto, A., Tanaka, Y., Ando, H. and Shimada, T.: Data Prefetching and Address Pre-Calculation through Instruction Pre-Execution with Two-Step Physical Register Deallocation, *Proc. Eighth Workshop on Memory Performance: Dealing with Applications, Systems and Architectures*, pp.41–48 (2007).
- 34) Yeager, K.C.: The MIPS R10000 Superscalar Microprocessor, *IEEE Micro*, Vol.16, No.2, pp.28–40 (1996).
- 35) Zilles, C. and Sohi, G.S.: Master/Slave Speculative Parallelization, *Proc. 35th Annual International Symposium on Microarchitecture*, pp.85–96 (2002).
- 36) Zilles, C.B. and Sohi, G.S.: Execution-Based Prediction using Speculative Slices, *Proc. 28th Annual International Symposium on Computer Architecture*, pp.2–13 (2001).

(Received January 14, 2008)

(Accepted March 21, 2008)



Akihiro Yamamoto was born in 1981. He received his B.E. and M.E. degrees from Nagoya University in 2004 and 2006, respectively. Since 2006, he has been engaged in development on SoC at Car Information System Design Department, Renesas Technology Corp.



Yusuke Tanaka received his B.E. degree from Nagoya University in 2006. He is currently a graduate student of the department of computational science and engineering of Nagoya University. His research interests include computer architectures.



Hideki Ando received his B.S. and M.S. degrees in electronic engineering from Osaka University, Suita, Japan in 1981 and 1983, respectively. He received a Ph.D. degree in information science from Kyoto University, Kyoto, Japan in 1996. From 1983 to 1997 he was engaged in the research and development of digital signal processors for ISDN, microprocessors for inference machines of the Japanese fifth-generation computer systems project, and general-purpose VLIW machines at the LSI Research and Development Laboratory, Mitsubishi Electric Corporation, Itami, Japan. From 1991 to 1992 he was a visiting scholar at Stanford University. In 1997 he joined the faculty of Nagoya University, Nagoya, Japan, where he is currently a professor in the department of computational science and engineering. In 1998 and 2002, he received the IPSJ best paper awards. His research interests include computer architecture and compilers.



Toshio Shimada received his B.S. and M.S. degrees in Mathematical Engineering and Instrumentation Physics in 1968 and 1970 respectively from the University of Tokyo. He received his PhD degree in Information Science and Technology in 1992 from the University of Tokyo. He had worked at Electrotechnical Laboratory from 1970 to 1992. He is currently a professor at Nagoya University. Dr. Shimada's research interests involve low power consumption processors and special purpose LSI.